

PRODUCT AND INSTALLATION MANUAL

wavin **OSMA**

OsmaDrain



wavin

OsmaDrain

Below Ground Drainage System



Contents

⊙ Introduction	2	⊙ Installation	35 – 51
The OsmaDrain System	2	Installation notes	35
⊙ Pipe and Joint Technology	3	Excavation	35
Material	3	Bedding	35
Standards	3	Backfill sequence	37
Acceptance	3	Pipe protection	37
⊙ General information	4	Jointing	39
⊙ Weights and Dimensions	5	Vertical Connections	41
⊙ Product Range Summary	6 – 8	Backdrop Connections	43
⊙ Product Details	9 – 32	Sealed Access Fittings	44
⊙ Transport, Handling and Storage	33 – 34	Sealed Rodding Access Fittings	45
Resources and Planning	33	Universal Gully	46
Transport	33	Bottle Gullies	47
Handling	33	Paved Area Gully – 4D860	48
Storage	34	Yard Gully	49
		Connections to Other Materials	50
		Wall Protection Sleeve	50
		Slotted Rigid Pipe	51
		⊙ Testing, Safety and Maintenance	52 – 53
		Testing	52
		Safety	52
		Maintenance	53
		⊙ Further Information	54

Introduction

OsmaDrain

OsmaDrain System

The OsmaDrain system is designed for use in gravity drainage installations with pipe and fittings being offered in 110mm and 160mm diameters.

The OsmaDrain range includes a wide variety of standard components such as Bends, Junctions and Rodding Access Fittings together with specialized fittings such as fully roddable Bottle Gullies.

OsmaDrain has a Stiffness Class of SN8 which makes it suitable for all adoptable and non-adoptable situations.

The OsmaDrain range offers two alternative means of access to underground drainage pipelines, giving Specifiers and Installers the freedom to choose the most suitable system for their needs.



Drainage Access Options

Sealed Access Fittings

(for use in either suspended drainage and/or traditional manhole applications).

Sealed Rodding Access Fittings

(for use where access is required to the drainage system for testing, inspection, maintenance and the removal of debris).

Pipe Production

OsmaDrain 110mm and 160mm pipe is of a multi-layer construction, manufactured using Wavin's innovative Next Generation Recycore® Technology to the requirements of: BS EN 13476-2 and uses over 50% of recycled material in its core. OsmaDrain 110mm and 160mm pipes have been extensively and independently tested and have proven to have the same performance characteristics as pipe conforming to BS EN 1401-1:2009.

Where applicable OsmaDrain components comply with the requirements of the following standards and are Kitemarked

accordingly i.e. BS EN 13476- 2, BS EN 1401-1 2009, BS 4660:1989/2000.

Where a British or European standard does not exist and again where applicable OsmaDrain fittings are covered by a British Board of Agrément Certificate.

RootSeal Technology

Now with even greater peace of mind. OsmaDrain snap cap and sealing rings now incorporate the green RootSeal Technology that uses a scientifically proven inhibitor to suppress tree root growth to help prevent them damaging pipe systems.

Fitting Design

The majority of OsmaDrain fittings are either single or double socketed components to provide total flexibility in use and to reduce installation time on site. The sockets of the components are specially designed to accommodate the co-injected, combined cap and seal – See Joint Design.

Pipe and Joint Technology

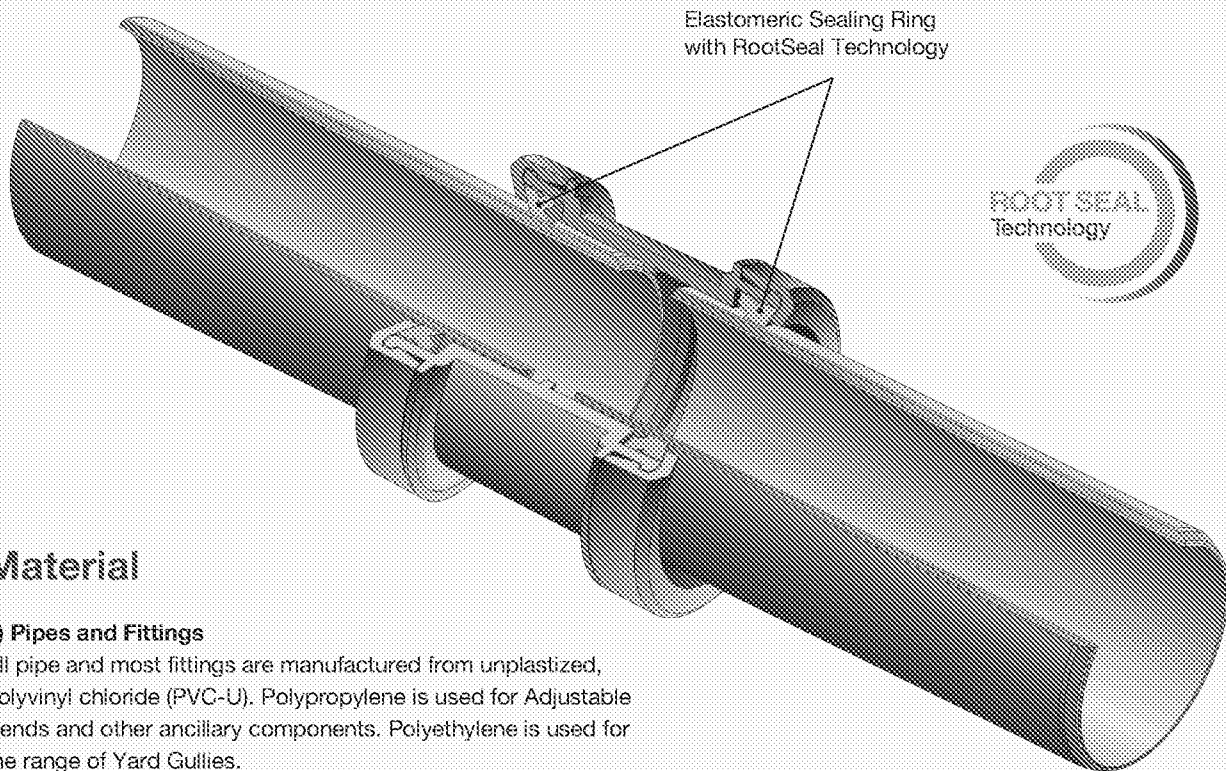

Material

a) Pipes and Fittings

All pipe and most fittings are manufactured from unplasticized, polyvinyl chloride (PVC-U). Polypropylene is used for Adjustable Bends and other ancillary components. Polyethylene is used for the range of Yard Gullies.

b) Sealing Rings

The OsmaDrain co-injection, RootSeal snap-cap and sealing ring concept is made from a combination of: Snap-Cap Polypropylene and Sealing Ring TPE. Where applicable, OsmaDrain 110mm and 160mm sockets are supplied complete with a captive ring seal.

Standards

🇬🇧 British Standards Institution

The OsmaDrain below ground drainage system complies where applicable with the requirements of the following British standards:

BS EN 1401 Plastics piping systems for non-pressure underground drainage and sewerage – Unplasticized poly(vinyl chloride) (PVC-U) – Part 1: Specifications for pipes, fittings and the system.

BS EN 13476-2 Plastics piping systems for non-pressure underground drainage and sewerage – PVC-U.

BS4660:1989/2000 Unplasticized polyvinyl chloride (PVC-U) pipes and plastic fittings of nominal size 110mm and 160mm for below ground gravity drainage and sewerage.

🇬🇧 British Board of Agrément

The OsmaDrain system has been awarded the following British Board Agrément certificate. 19/5622 OsmaDrain Underground Drainage.

Acceptance

OsmaDrain systems are included in the following publication:- Sewers for Adoption, 6th, 6A and 7th Editions, under clause 5.2.21 and 5.2.22.

Meets with the requirements of Ofwat's Design and Construction Guidance (DCG) April 2020.

General Information

OsmaDrain

Descriptions

Descriptions and illustrations in this publication are for guidance only. The fittings illustrated are generally typical of the OsmaDrain 110mm sizes. No responsibility can be accepted for any errors, omissions or incorrect assumptions. Refer to the product itself if more detailed information is required. Due to the continuing programme of product improvement the Company reserves the right to amend any published information or to modify any product without prior notice.

Dimensions

Unless otherwise stated all dimensions are in millimetres (mm).

Symbols

a) British Standard Kitemark

Identifies pipes and fittings which are manufactured under the B.S.I. Certification Scheme.

b) British Board of Agrément

Identifies non-Kitemarked fittings which are covered by a British Board of Agrément Certificate.

Colour

Most pipe and fittings – Golden Brown
Ring Seals – Green or Black

Supply

All OsmaDrain components are supplied through a nationwide network of merchant distributors. For further information contact Customer Services on 0800 038 0088.

Technical advice

The OsmaDrain System is backed by Wavin's comprehensive technical advice service. This is available to provide expert assistance at every stage of a project, from planning and product selection to installation and maintenance.

Contact Wavin Technical Design Department:

 or via online enquiry
at wavin.co.uk

Literature

The following Wavin publications are also available from the Literature Department at Chippenham.

General

- ① Wavin Below Ground & Civils System: Trade Price List

Stormwater Management Systems

- ① Wavin AquaCell System:
Product and Installation Manual
- ① Wavin Q-Bic Plus:
Product and Installation Manual
- ① Wavin AquaGrid:
Product and Installation Manual
- ① Wavin Vortex Valves:
Product Overview
- ① Wavin Civils Channel Systems:
Product and Installation Manual
- ① Wavin TwinWall:
Product Guide

Gravity Drain and Sewer Systems

- ① Osma UltraRib System:
Product and Installation Manual
- ① Osma and Wavin Inspection Chamber Range:
Product and Installation Manual

To request details with regards to any of the above components and/or for any technical enquires please contact:

Literature Request

Tel: 0800 038 0088

Email: customerservice.uk@wavin.com

Technical Design

Tel: 0800 038 0088

Email: technical.design.uk@wavin.com

Wavin Online

The complete range of Wavin/Osma product and installation guides are also available online at: wavin.co.uk

Weights and Dimensions

The following pages illustrate the 110mm and 160mm OsmoDrain range of underground gravity drainage and sewerage pipes, fittings and accessories. Part numbers, descriptions, dimensions and weights of pipe are included.

The OsmoDrain range of 110/160mm pipes comply with the requirements of BS EN 13476-2 with a ring stiffness SN8 8kN/m² and are Kitemarked in accordance with the BSI certification scheme. OsmoDrain pipe is supplied in two diameters, 110mm and 160mm, plain ended and in standard lengths of either 3 or 6 metres.

Table 1: Pipe weights

Plain Ended (P/E)

Nominal Size (mm)	Length (m)	Weight (kg/m)	Part Number
110	3	1.6	4D073 ▼
	6		4D076 ▼
160	3	3.0	6D073 ▼
	6		6D076 ▼

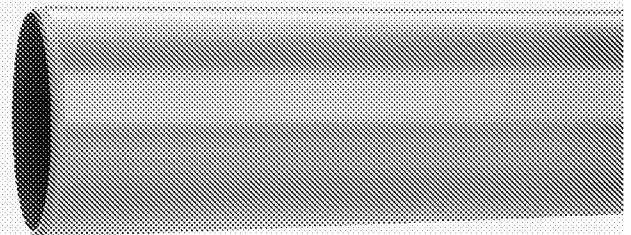

Plain Ended (P/E) – Slotted

Nominal Size (mm)	Length (m)	Weight (kg/m)	Slot Size (mm)	Slot Centres (mm)	Number of Rows	θ	Part Number
110	6	1.6	36 x 2.5	67	2	120°	4D066 ▼
160	6	3.0	36 x 2.5	67	2	120°	6D066 ▼

Table 2: Pipe and fitting dimensions

Underground Drainage

Nominal Size (mm)			110	160
Wall Thickness	Pipe	min	3.2	4.1
	Fittings	min	3.2	4.1
	Junctions	min	3.8	4.1
Mean outside diameter pipe and fittings spigot		min	110.0	160.0
		max	110.4	160.6
Extreme individual OD pipe and fittings spigot		min	108.0	157.1
		max	112.4	163.5

Table 3: Socket dimensions

Typical Ring Seal Sockets

Nominal Size (mm)	OD	A
110	132	58
160	191	75

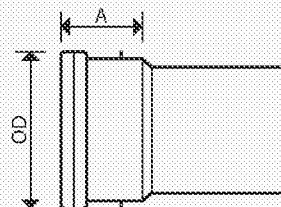

Table 4: Size of block bundles

Nominal Size (mm)	Number of 3m/6m lengths per bundle	Dimensions (mm)		Weight per bundle (kg)	
		height	width	3m	6m
110	50	725	1145	240	480
160	25	865	1035	225	450

Product Range Summary

OsmaDrain

The Product Range Summary lists the range of pipes and fittings detailed in the Product Range.

Abbreviations

P/E - Pipes and Fittings with both ends plain or with one plain end and one special end.

S/S - Pipes and Fittings with one or more ring-seal or push-fit sockets, but always one plain or special end.

D/S - Fittings with ring-seal or push-fit sockets at all ends.

Table 5: The Product Range Summary

Product Description	Nominal Size (mm)	T10	T60	Page
Pipe – solid	P/E Pipe – 3 metre	☉	☉	9
	P/E Pipe – 6 metre	☉	☉	9
Pipe – slotted	P/E Pipe – 6 metre	☉	☉	9
Coupler	D/S Coupler – for slotted pipe	☉	☉	9
	D/S Slip Coupler	☉	☉	9
	D/S Pipe Coupler	☉	☉	10
Socket	S/S Settlement Socket	☉		10
Sleeve	P/E Protection Sleeve	☉		10
Adaptors	D/S Adaptor – to thickwall clay	☉	☉	10
	D/S Adaptor – to thinwall clay	☉	☉	11
	Rainwater Adaptor – to 68mm round	☉		11
	Universal Rainwater Adaptor	☉		11
	D/S Adaptor – 32mm waste pipe	☉		11
	D/S Adaptor – 40mm waste pipe	☉		11
	D/S Adaptor – 50mm waste pipe	☉		11
	Internal Drain Connector – 32/40mm waste	☉		12
	Internal Drain Connector – 50mm waste	☉		12
Internal Drain Connector – to soil stack	☉		12	
Cap	Temporary Site Cap	☉		12
Reducers	S/S Level Invert Reducer – 82mm OsmaDrain	☉		12
	S/S Level Invert Reducer – 110mm OsmaDrain		☉	12
Short Radius Bends	S/S Bend – 87.5°	☉	☉	13
	S/S Bend – 67.5°	☉		13
	S/S Bend – 45°	☉	☉	13
	S/S Bend – 30°	☉	☉	13
	S/S Bend – 15°	☉	☉	13
	S/S Bend – 11.25°	☉		14
	D/S Bend – 87.5°	☉	☉	14
	D/S Bend – 67.5°	☉		14
	D/S Bend – 45°	☉	☉	14
	D/S Bend – 30°	☉	☉	14
	D/S Bend – 15°	☉	☉	15
	D/S Bend – 11.25°	☉		15

Product Description	Nominal Size (mm)	110	160	Page
Adjustable Bends	S/S Bend – 0° – 30°	☉		15
	D/S Bend – 0° – 30°	☉		15
Long Radius Bends	P/E Long Radius Bend – 90°	☉	☉	15
	P/E Long Radius Bend – 45°	☉	☉	16
	S/S Long Radius Bend – 87.5° with 900mm spigot	☉		16
	S/S Long Radius Bend – 45°	☉		16
	D/S Long Radius Rest Bend – 87.5°	☉		16
	D/S Long Radius Bend – 45°	☉		17
Equal Junctions	S/S Junction – 87.5°	☉	☉	17
	D/S Junction – 87.5°	☉	☉	17
	S/S Junction – 45°	☉	☉	17
	D/S Junction – 45°	☉	☉	17
Unequal Junctions	S/S Junction – 87.5°– 160mm x 110mm		☉	18
	D/S Junction – 87.5°– 160mm x 110mm		☉	18
	S/S Junction – 45°– 160mm x 110mm		☉	18
	D/S Junction – 45°– 160mm x 110mm		☉	18
Anti-Flood Valves	S/S Anti-flood Valve – single valve, for surface water only	☉	☉	19
Sealed Access Fittings	S/S Inspection Pipe	☉		19
	S/S Equal Double Inspection Junction – 45°	☉		19
Sealed Rodding Eyes	P/E Rodding Eye – Straight – 15kN (1.5 Tonnes)	☉	☉	19
	S/S Rodding Eye – 45°– 15kN (1.5 Tonnes)	☉		20
Screwed Access Fittings	P/E Screwed Access Cover	☉	☉	20
	S/S Screwed Access Cover	☉	☉	20
	S/S Short Radius Access Bend – 87.5°	☉		20
	S/S Access Pipe	☉	☉	21
	D/S Short Radius Access Bend – 87.5°	☉		21
	D/S Equal Access Junction – 87.5°	☉		21
Socket Plugs	Socket Plug	☉		21
	P/E Socket Plug – closed boss socket	☉		22
	P/E Socket Plug		☉	22
	P/E Socket Plug – open boss socket	☉		22
Universal Gully Fittings	S/S Universal Gully Trap	☉		22
	P/E Plain Hopper	☉		23
	P/E Vertical Inlet Hopper	☉		23
	P/E Sealed Access Hopper	☉		23
	SW/S Plain Hopper	☉		23
	SW/S Vertical Inlet Hopper	☉		23
	S/S Bossed Pipe	☉		24
	Sealed Access Cover	☉		24

Product Range Summary

OsmaDrain

Product Description	Nominal Size (mm)	110	160	Page
Bottle Gullies	P/E Access Gully	☉		24
	S/S Paved Area Gully	☉		24
	Sealed Cover Plate – for paved area gully only	☉		24
	Metal Grid Gully Cover – for paved area gully only	☉		25
	S/S Bottle Gully – 87.5°	☉		25
	S/SW Bottle Gully – 87.5° – back boss open	☉		25
	Sealed Access Cover – for bottle gully only	☉		25
	Bottle Gully Riser – for bottle gully only	☉		25
	DI Grating – for bottle gully only	☉		26
Yard Gully	P/E Trapped Yard Gully – 300mm dia	☉		26
	Grating and Frame	☉		26
	Perforated Galvanised Catchment Bucket	☉		26
Suspended Bracketing System	Adjustable Pipe Bracketing Assembly	☉		27
	Adjustable Socket Bracket and Brace Assembly	☉		27
Testing Equipment	Stopper for Testing	☉	☉	28
Cleaners, Solvent Cements & Lubricants	De-greasing Cleaner No 1 – 250ml can	☉	☉	28
	Solvent Cement No 2 – 125ml can	☉	☉	29
	Soluble Lubricant	☉	☉	29
Spares	Spares	☉	☉	29-32

Product Details Building Drainage System 110-160mm

Pipe

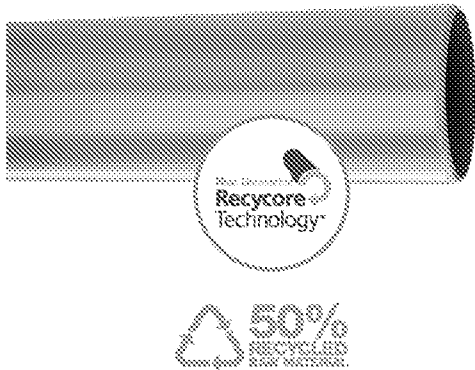

P/E Pipe

- 3 metre and 6 metre lengths

Material: PVC-U

Nominal Size (mm)	Part Number	Length (m)
110	4D073 ♡	3.0
160	6D073 ♡	3.0
110	4D076 ♡	6.0
160	6D076 ♡	6.0

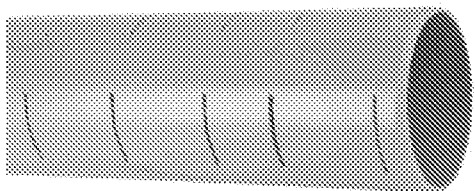

P/E Slotted Pipe

- 6 metre lengths

Material: PVC-U

Nominal Size (mm)	Part Number	Length (m)
110	4D066 ♡	6.0
160	6D066 ♡	6.0

Couplers

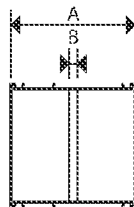
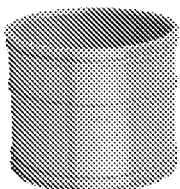

D/S Coupler

- For jointing OsmaDrain slotted pipe

Material: PVC-U

Nominal Size (mm)	Part Number	Dimensions (mm)	
		A	B
110	4D104	98	2
160	6D104	119	2

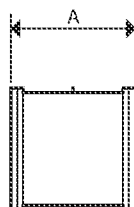
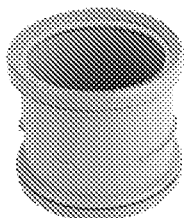

D/S Slip Coupler

- For new branch entry connections and repairs

Material: PVC-U

Nominal Size (mm)	Part Number	Dimensions (mm)
		A
110	4D105 ♡	115
160	6D105 ♡	145

OsmaDrain

Product Details Building Drainage System 110-160mm

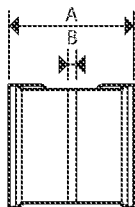
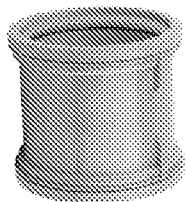

D/S Pipe Coupler

- For jointing OsmaDrain pipe

Material: PVC-U

Nominal Size (mm)	Part Number	Dimensions (mm)	
		A	B
110	4D205 ♡	118	2
160	6D205 ♡	152	2

Socket

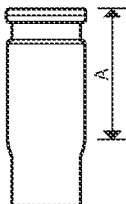
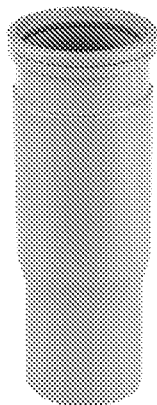

S/S Settlement Socket

- Expansion joint, installed vertically to accommodate differential settlement

Material: PVC-U

Nominal Size (mm)	Part Number	Dimensions (mm)
		A
110	4D115	223

Sleeve

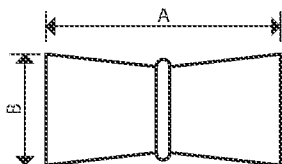
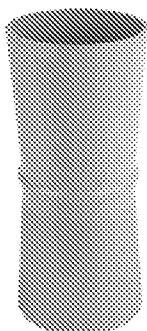

Protection Sleeve

- For protection of pipe passing through walls

Material: PVC-U

Nominal Size (mm)	Part Number	Dimensions (mm)	
		A	B
110	4D131	310	138

Adaptors

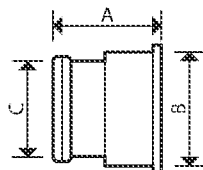
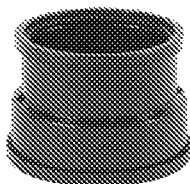

D/S Adaptor to Clay

- For connecting OsmaDrain to thickwall clay spigot

Material: Polypropylene

Nominal Size (mm)	Part Number	Dimensions (mm)		
		A	B	C
110	4D127	110	135	110
160	6D127	110	185	160

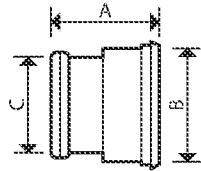
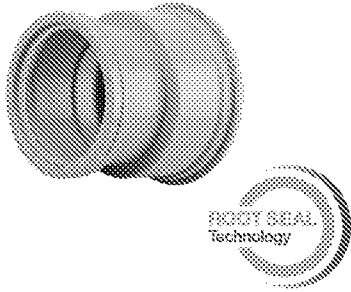

D/S Adaptor

- Connector to BS EN 295 thinwall clay spigot

Material: Polypropylene

Nominal Size (mm)	Part Number	Dimensions (mm)		
		A	B	C
110	4D129	135	132	110
160	6D129	185	184	160

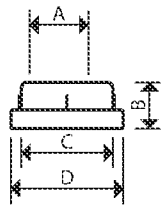
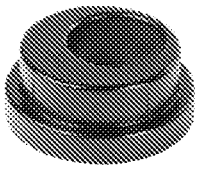

Rainwater Adaptor

- For connecting 68mm round PVC-U RW pipe to 110mm OsmaDrain socket or spigot, external use only

Material: Polypropylene

Nominal Size (mm)	Part Number	Dimensions (mm)			
		A	B	C	D
110	4D149	70	55	110	136

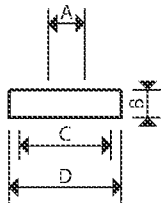
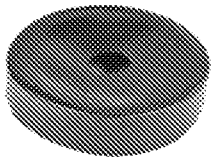

Universal Drain Adaptor

- For connecting square/round rainwater downpipes up to 70mm, or waste pipe from 32mm up to 50mm, to 110mm OsmaDrain socket or spigot
- External use only

Material: EPDM

Nominal Size (mm)	Part Number	Dimensions (mm)			
		A	B	C	D
110	4D159	30	30	110	136

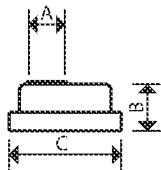
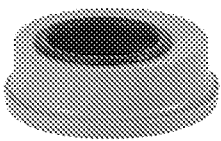

D/S Adaptor to Waste Pipe

- For connecting 32mm up to 50mm waste pipe, to 110mm OsmaDrain spigot

Material: Polypropylene

Nominal Size (mm)	Part Number	Dimensions (mm)		
		A	B	C
32x110	4D287	32	40	110
40x110	4D288	40	40	110
50x110	4D286	50	40	110

OsmaDrain

Product Details Building Drainage System 110-160mm

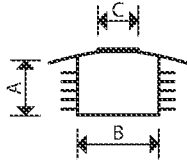

Internal Drain Connector

- For connecting 32mm up to 50mm waste pipe to 110mm OsmaDrain spigot

Material: EPDM

Nominal Size (mm)	Part Number	Dimensions (mm)		
		A	B	C
32/40x110	4D298	55	95	25-40
50x110	4D299	55	95	45-55

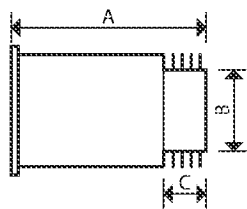
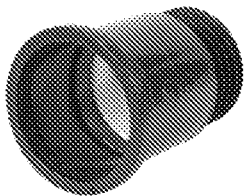

Internal Drain Connector to Soil Stacks

- For connecting 110mm PVC-U to OsmaDrain 110mm spigot

Material: Polypropylene

Nominal Size (mm)	Part Number	Dimensions (mm)		
		A	B	C
110	4D464	175	95	55

Temporary Site Cap

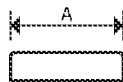
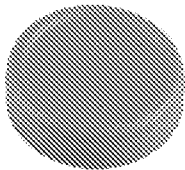

Temporary Site Cap

- For blanking off a 110mm OsmaDrain socket or spigot

Material: Polypropylene

Nominal Size (mm)	Part Number	Dimensions (mm)
		A
110	4D295	110

Reducers

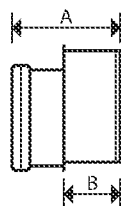
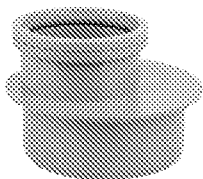

S/S Level Invert Reducer

- To 82mm/110mm OsmaDrain

Material: PVC-U

Nominal Size (mm)	Part Number	Dimensions (mm)	
		A	B
110	4D095	103	53
160	6D099	127	70

Short Radius Bends

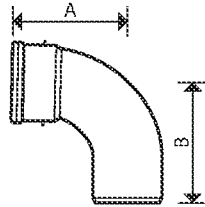
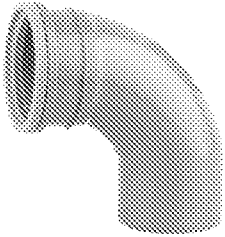

S/S Short Radius Bend - 90°

Material: PVC-U

Nominal Size (mm)	Part Number	Dimensions (mm)	
		A	B
110	4D161 ▼	160	162
160	6D161 ▼	247	240

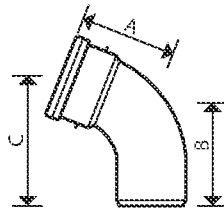
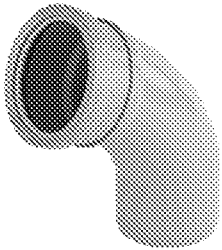

S/S Short Radius Bend - 45°

Material: PVC-U

Nominal Size (mm)	Part Number	Dimensions (mm)		
		A	B	C
110	4D162 ▼	155	151	214

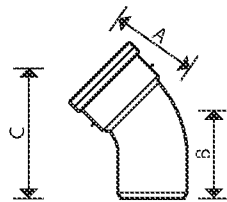
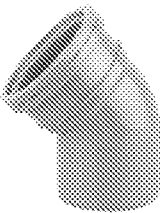

S/S Short Radius Bend - 30°

Material: PVC-U

Nominal Size (mm)	Part Number	Dimensions (mm)		
		A	B	C
110	4D163 ▼	96	92	158
160	6D163 ▼	140	118	215

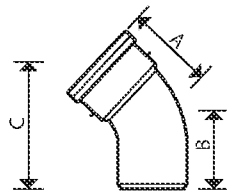
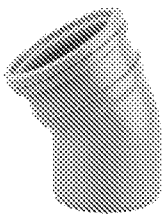

S/S Short Radius Bend - 15°

Material: PVC-U

Nominal Size (mm)	Part Number	Dimensions (mm)		
		A	B	C
110	4D166 ▼	92	95	162
160	6D166 ▼	127	127	240

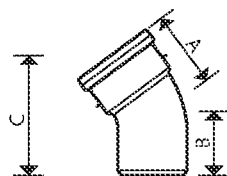
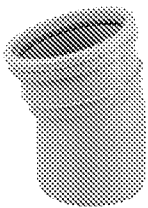

S/S Short Radius Bend - 7.5°

Material: PVC-U

Nominal Size (mm)	Part Number	Dimensions (mm)		
		A	B	C
110	4D167 ▼	94	93	180
160	6D167 ▼	117	115	232

OsmaDrain

Product Details Building Drainage System 110-160mm

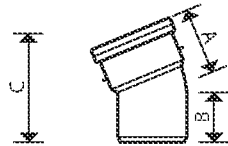

5/S Short Radius Bend - 11.25°

Material: PVC-U

Nominal Size (mm)	Part Number	Dimensions (mm)		
		A	B	C
110	4D168 ▼	84	88	173

Double Socket

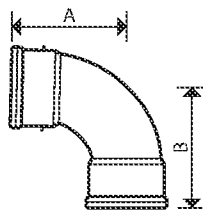
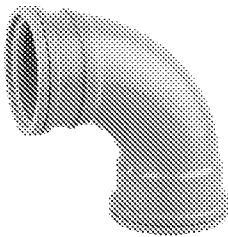

D/S Short Radius Bend - 87.5°

Material: PVC-U

Nominal Size (mm)	Part Number	Dimensions (mm)	
		A	B
110	4D561 ▼	175	160
160	6D561 ▼	260	247

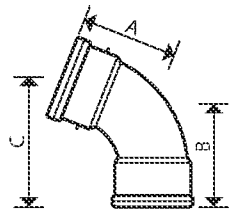
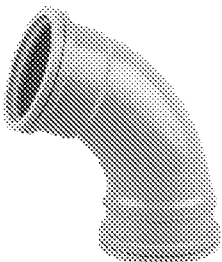

D/S Short Radius Bend - 87.5°

Material: PVC-U

Nominal Size (mm)	Part Number	Dimensions (mm)		
		A	B	C
110	4D562 ▼	151	151	208

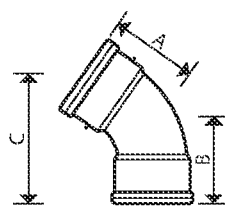
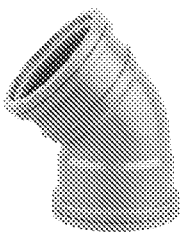

D/S Short Radius Bend - 45°

Material: PVC-U

Nominal Size (mm)	Part Number	Dimensions (mm)		
		A	B	C
110	4D563 ▼	96	94	160
160	6D563 ▼	128	141	225

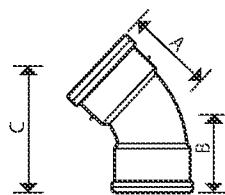
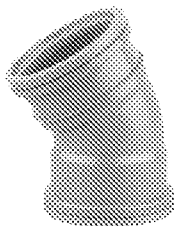

D/S Short Radius Bend - 30°

Material: PVC-U

Nominal Size (mm)	Part Number	Dimensions (mm)		
		A	B	C
110	4D566 ▼	92	92	168
160	6D566 ▼	127	127	240

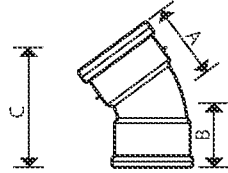
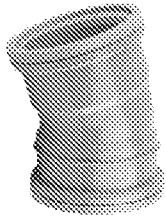

D/S Short Radius Bend – 15°

Material: PVC-U

Nominal Size (mm)	Part Number	Dimensions (mm)		
		A	B	C
110	4D567 ▼	84	83	164
160	6D567 ▼	117	117	232

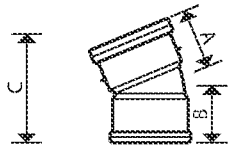
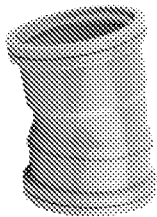

D/S Short Radius Bend – 11.25°

Material: PVC-U

Nominal Size (mm)	Part Number	Dimensions (mm)		
		A	B	C
110	4D568 ▼	84	84	173

Adjustable Bends

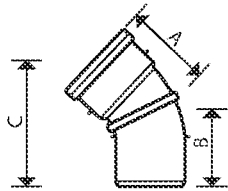
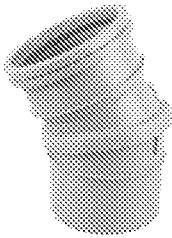

S/S Adjustable Bend – 30°

- For variable angles up to 30°, rotate segments to achieve required angle

Material: Polypropylene

Nominal Size (mm)	Part Number	Dimensions (mm)		
		A	B	C
110	4D173 ▲	97	90	180

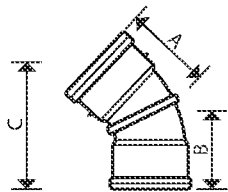
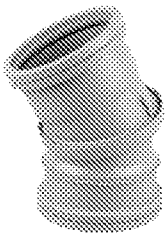

D/S Adjustable Bend – 9.30°

- For variable angles up to 30°, rotate segments to achieve required angle

Material: Polypropylene

Nominal Size (mm)	Part Number	Dimensions (mm)		
		A	B	C
110	4D573 ▲	97	97	184

Long Radius Bends

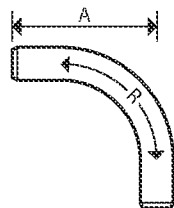

P/E Long Radius Bend – 90°

Material: PVC-U

Nominal Size (mm)	Part Number	Dimensions (mm)	
		A	R
110	4D281 ▼	690	460*
160	6D281 ▼	850	690*

*Note: dimension R = centre line radius

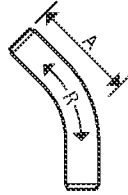

P/E Long Radius Bend - 45°

Material: PVC-U

Nominal Size (mm)	Part Number	Dimensions (mm)	
		A	R
110	4D283 ▼	310	460*
160	6D283 ▼	460	690*

*Note: dimension R = centre line radius

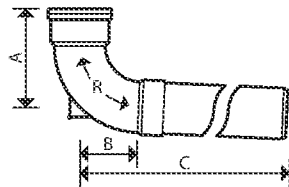

S/S Long Radius Bend - 87.5°

- With spigot length 900mm effective

Material: PVC-U

Nominal Size (mm)	Part Number	Dimensions (mm)			
		A	B	C	R
110	4D181 ▼	282	220	900	250*

*Note: dimension R = centre line radius

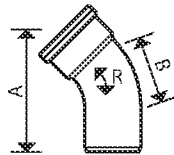
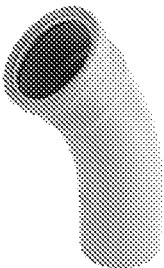

S/S Long Radius Bend - 45°

Material: PVC-U

Nominal Size (mm)	Part Number	Dimensions (mm)		
		A	B	R
110	4D183 ▼	292	165	250*

*Note: dimension R = centre line radius

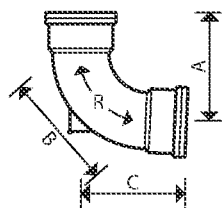
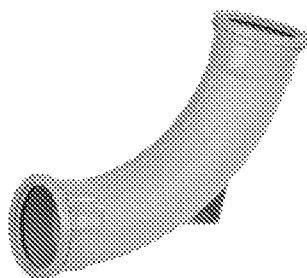

D/S Long Radius Rest Bend - 87.5°

- Satisfies recommendations of BS 5572: 1994 for base of soil stack applications
- Manufactured with cut out marks to convert bend to a Channel Bend for use within traditional manholes

Material: PVC-U

Nominal Size (mm)	Part Number	Dimensions (mm)			
		A	B	C	R
110	4D581 ▼	290	282	285	250*

*Note: dimension R = centre line radius

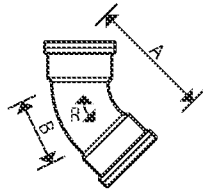
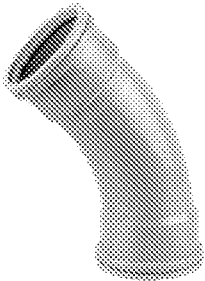

D/S Long Radius Bend – 45°

Material: PVC-U

Nominal Size (mm)	Part Number	Dimensions (mm)		
		A	B	R
110	4D583 ▼	290	165	250*

*Note: dimension R = centre line radius

Equal Junctions

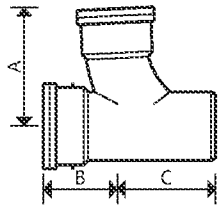
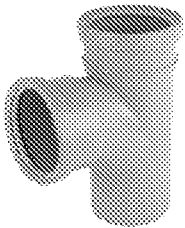

6/S Equal Junction – 87.5°

Material: PVC-U

Nominal Size (mm)	Part Number	Dimensions (mm)		
		A	B	C
110	4D190 ▼	150	120	142
160	6D190 ▼	230	170	230

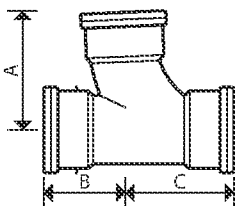
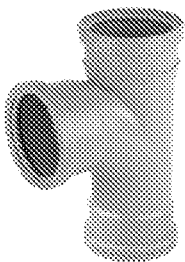

D/S Equal Junction – 87.5°

Material: PVC-U

Nominal Size (mm)	Part Number	Dimensions (mm)		
		A	B	C
110	4D193 ▼	150	120	155
160	6D193 ▼	232	170	218

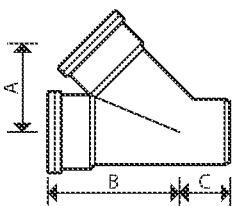
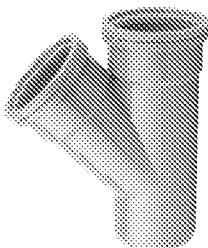

6/S Equal Junction – 45°

Material: PVC-U

Nominal Size (mm)	Part Number	Dimensions (mm)		
		A	B	C
110	4D210 ▼	142	220	68
160	6D210 ▼	214	341	106

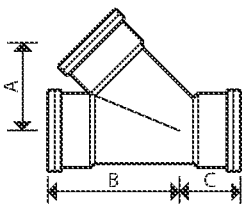
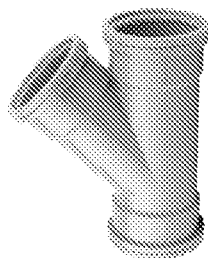

D/S Equal Junction – 45°

Material: PVC-U

Nominal Size (mm)	Part Number	Dimensions (mm)		
		A	B	C
110	4D213 ▼	142	202	99
160	6D213 ▼	214	307	140

Unequal Junctions

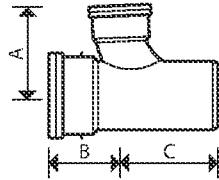
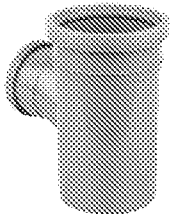

S/S Unequal Junction ~ 87.5°

Material: PVC-U

Nominal Size (mm)	Part Number	Dimensions (mm)		
		A	B	C
160x110	6D198 ▼	205	156	200

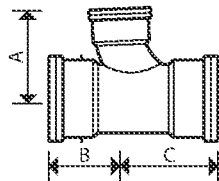
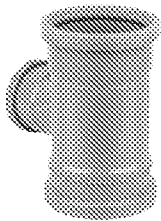

D/S Unequal Junction ~ 87.5°

Material: PVC-U

Nominal Size (mm)	Part Number	Dimensions (mm)		
		A	B	C
160x110	6D199 ▼	205	156	220

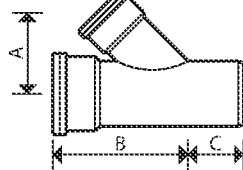
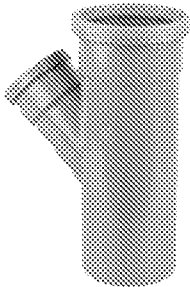

S/S Unequal Junction ~ 45°

Material: PVC-U

Nominal Size (mm)	Part Number	Dimensions (mm)		
		A	B	C
160x110	6D218 ▼	187	307	140

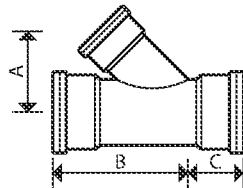
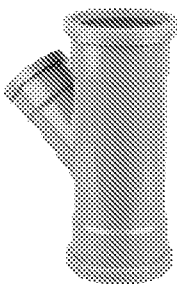

D/S Unequal Junction ~ 45°

Material: PVC-U

Nominal Size (mm)	Part Number	Dimensions (mm)		
		A	B	C
160x110	6D219 ▼	187	307	140

Anti-Flood Valves

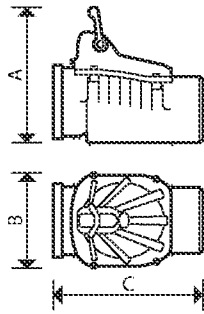
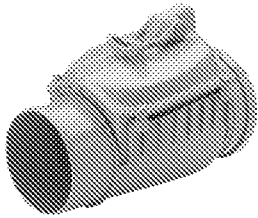

S/S Anti-Flood Valve

- For surface and foul water applications
- Single valve

Material: PVC-U

Nominal Size (mm)	Part Number	Dimensions (mm)		
		A	B	C
110	4D921	266	188	287
160	6D921	333	243	367

Sealed Access Fittings

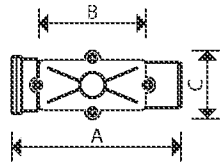
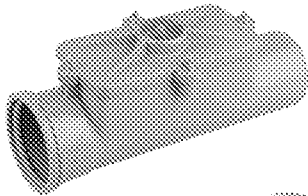

S/S Inspection Pipe

- With removable rectangular cover and airtight sealing ring
- For use within traditional manholes or suspended drainage installations

Material: PVC-U

Nominal Size (mm)	Part Number	Dimensions (mm)		
		A	B	C
110	4D420 ▽	397	230	115

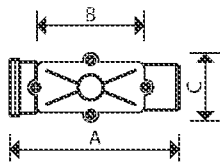
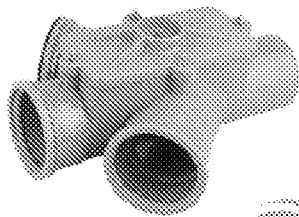

S/S Equal Double Inspection Junction - 45°

- With removable rectangular cover and airtight sealing ring
- For use within traditional manholes or suspended drainage installations

Material: PVC-U

Nominal Size (mm)	Part Number	Dimensions (mm)			
		A	B	C	D
110	4D492 ▽	397	230	115	141



Sealed Rodding Eyes

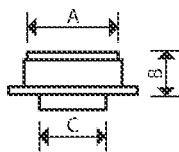
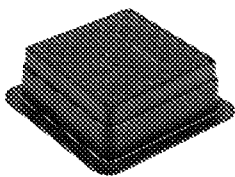

P/E Rodding Eye

- Square, sealed access cover, suitable for use in situations requiring a loading up to 15kN (1.5 Tonnes), where the frame of the cover is supported by a concrete plinth
- Use in conjunction with D/S Bend (Spare cover 4D702)

Material: PVC-U

Nominal Size (mm)	Part Number	Dimensions (mm)		
		A	B	C
110	4D360	172	82	110
160	6D360	172	82	160

OsmaDrain

Product Details Building Drainage System 110-160mm

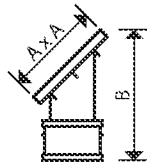

S/S Square Top Flooding Point

- Sealed, c/w coupling

Material: PVC-U

Nominal Size (mm)	Part Number	Dimensions (mm)	
		A x A	B
110	4D361	160x160	255

Screwed Access Fittings

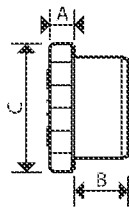

P/E Screwed Access Cover

- Allows full bore access to the drainage system for cleaning
- Fits into a standard OsmaDrain ring seal socket

Material: PVC-U

Nominal Size (mm)	Part Number	Dimensions (mm)		
		A	B	C
110	4D292 ▽	36	50	130
160	6D292 ▽	41	58	196

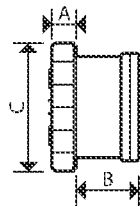
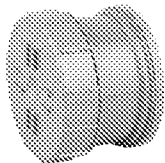

S/S Screwed Access Cover

- Allows full bore access to the drainage system for cleaning
- Fits over a standard OsmaDrain spigot

Material: PVC-U

Nominal Size (mm)	Part Number	Dimensions (mm)		
		A	B	C
110	4D290 ▽	36	60	130
160	6D290 ▽	41	68	196

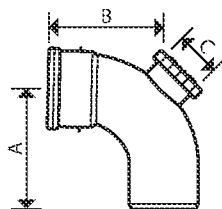
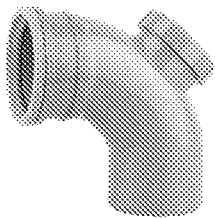

S/S Short Radius Access Bend ~ 87.5°

- Allows access via screwed access cover to the drainage system for cleaning

Material: PVC-U

Nominal Size (mm)	Part Number	Dimensions (mm)		
		A	B	C
110	4D169 ▽	165	160	80*

*Note: dimension C = aperture opening



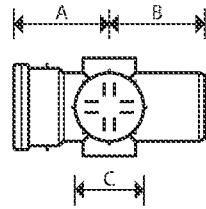
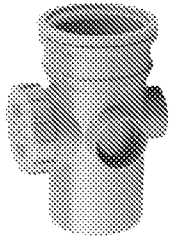

S/S Access Pipe

- Allows access via screwed access cover to the drainage system for cleaning

Material: PVC-U

Nominal Size (mm)	Part Number	Dimensions (mm)		
		A	B	C
110	4D274 ▼	95	118	130
160	6D274 ▼	124	155	196

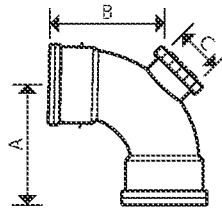
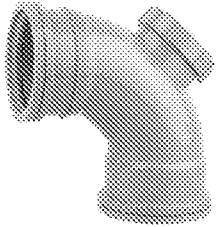

D/S Short Radius Access Bend - 87.5°

- Allows access via screwed access cover to the drainage system for cleaning

Material: PVC-U

Nominal Size (mm)	Part Number	Dimensions (mm)		
		A	B	C
110	4D569 ▼	175	160	80*

*Note: dimension C = aperture opening

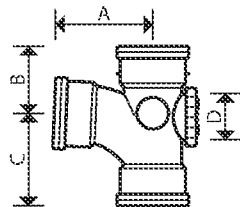
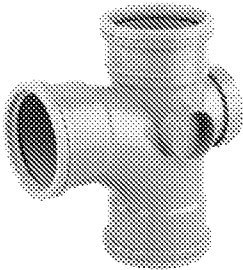

D/S Equal Access Junction - 87.5°

- Allows access via screwed access cover to the drainage system for cleaning

Material: PVC-U

Nominal Size (mm)	Part Number	Dimensions (mm)			
		A	B	C	D
110	4D593 ▼	170	120	172	80*

*Note: dimension D = aperture opening

Socket Plugs

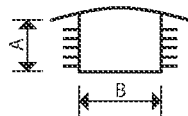
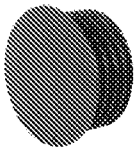

Socket Plug

- Fits into 110mm pipe

Material: Polypropylene/Rubber

Nominal Size (mm)	Part Number	Dimensions (mm)	
		A	B
110	4D291 ▼	55	95

OsmaDrain

Product Details Building Drainage System 110-160mm

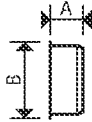

P/E Socket (Closed) Plug

- Incorporates one closed boss socket position, will form either a 32mm, 40mm or 50mm waste pipe connection when fitted with the appropriate boss socket adaptor
- Fits into 110mm socket

Material: PVC-U

Nominal Size (mm)	Part Number	Dimensions (mm)	
		A	B
110	4D296 ▼	54	132

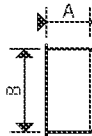
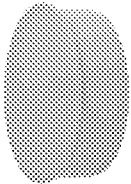

P/E Socket Plug

- Allows full bore access to the drainage system for cleaning, fits into a standard OsmaDrain ring seal socket

Material: PVC-U

Nominal Size (mm)	Part Number	Dimensions (mm)	
		A	B
160	6D296 ▼	91	192

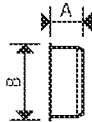

P/E Socket (Open) Plug

- Incorporates one open boss socket position, will form either a 32mm, 40mm or 50mm waste pipe connection when fitted with the appropriate boss socket adaptor
- Fits into 110mm socket

Material: PVC-U

Nominal Size (mm)	Part Number	Dimensions (mm)	
		A	B
110	4D297 ▼	54	132

Universal Gully Fittings

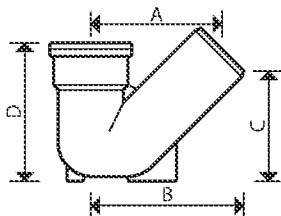
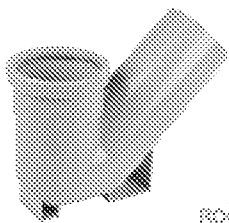

S/S Universal Gully Trap

- To obtain 'P', 'Q' or 'S' trap add appropriate 45° or 87.5° OsmaDrain bend

Material: PVC-U

Nominal Size (mm)	Part Number	Dimensions (mm)			
		A	B	C	D
110	4D500 ▲	220	300	175	205

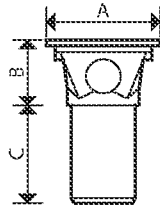
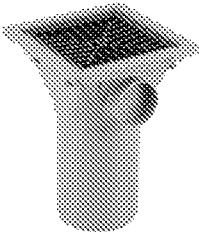

P/E Plain Hopper

- With 150mm long spigot

Material: PVC-U

Nominal Size (mm)	Part Number	Dimensions (mm)		
		A	B	C
110	4D507 ▲	183	98	156

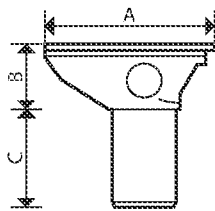
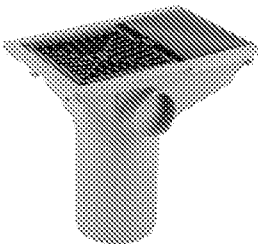

P/E Vertical Inlet Hopper

- With 150mm long spigot

Material: PVC-U

Nominal Size (mm)	Part Number	Dimensions (mm)		
		A	B	C
110	4D508 ▲	272	98	156

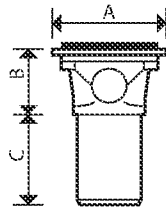
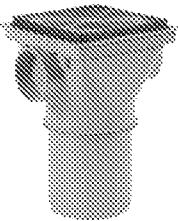

P/E Sealed Access Hopper

- With 150mm long spigot

Material: PVC-U

Nominal Size (mm)	Part Number	Dimensions (mm)		
		A	B	C
110	4D527 ▲	183	98	156

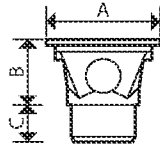
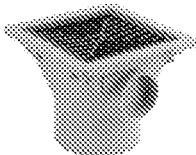

SW/S Plain Hopper

- With solvent socket

Material: PVC-U

Nominal Size (mm)	Part Number	Dimensions (mm)		
		A	B	C
110	4D503 ▲	183	98	51

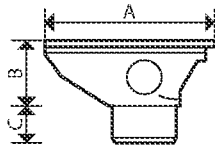
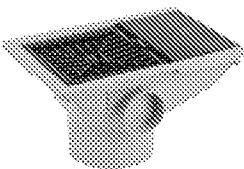

SW/S Vertical Inlet Hopper

- With solvent socket

Material: PVC-U

Nominal Size (mm)	Part Number	Dimensions (mm)		
		A	B	C
110	4D504 ▲	272	98	53

OsmaDrain

Product Details Building Drainage System 110-160mm

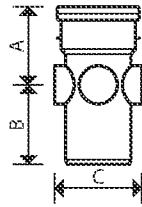
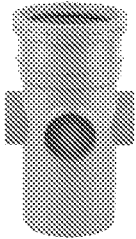

S/S Boresed Pipe

- With four boss sockets

Material: PVC-U

Nominal Size (mm)	Part Number	Dimensions (mm)		
		A	B	C
110	4D589 ▲	126	126	148

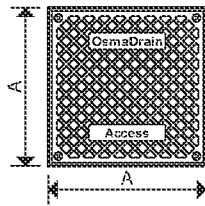
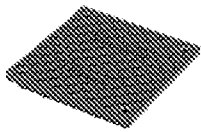

Sealed Access Cover

- For Universal Plain Hoppers complete with sealing ring and screws

Material: PVC-U

Nominal Size (mm)	Part Number	Dimensions (mm)
		A
-	4D526 ▲	160

Bottle Gullies

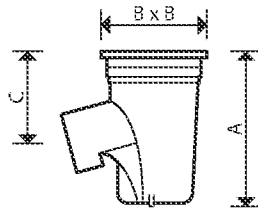
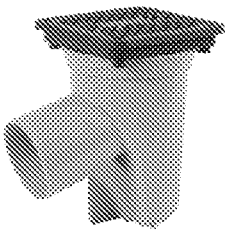

P/E Access Gully

- Square with rotating top and grid

Material: Polypropylene

Nominal Size (mm)	Part Number	Dimensions (mm)		
		A	BxB	C
110	4D850	270	191x191	170

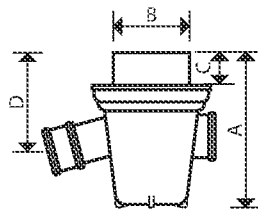
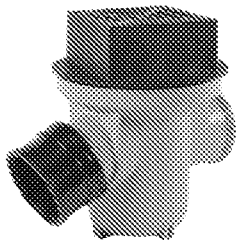

S/S Paved Area Gully

Material: Polypropylene

Nominal Size (mm)	Part Number	Dimensions (mm)			
		A	B	C	D
110	4D860	335	168	75	245

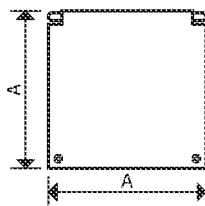

Sealed Cover Plate

- For use with 4D860 Paved Area Gully only

Material: Polypropylene

Nominal Size (mm)	Part Number	Dimensions (mm)
		A
-	4D862	154

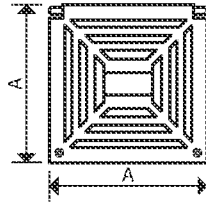
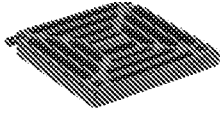

Metal Grid Gully Cover

- For use with 4D860 Paved Area Gully only

Material: Ductile Iron

Nominal Size (mm)	Part Number	Dimensions (mm) A
-	4D863	154

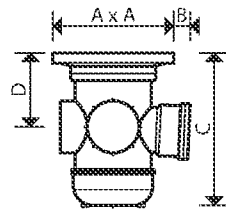
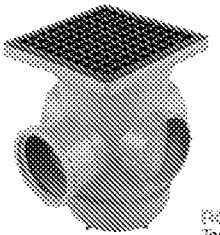

S/S Bottle Gully – 87.5"

- Provides access to the drainage system for cleaning, supplied with all bosses closed

Material: PVC-U

Nominal Size (mm)	Part Number	Dimensions (mm) A x A	B	C	D
110	4D900	228x228	62	317	157

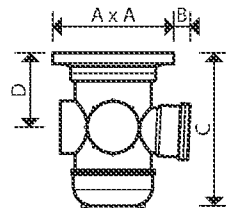
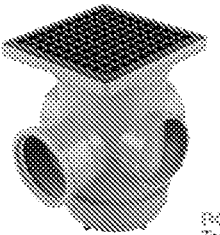

S/SW Bottle Gully – 87.5"

- Provides access to the drainage system for cleaning, supplied with side bosses closed but with 110mm back boss open

Material: PVC-U

Nominal Size (mm)	Part Number	Dimensions (mm) A x A	B	C	D
110	4D901	228x228	62	317	157

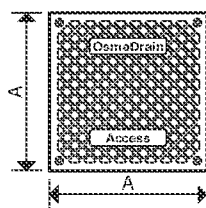
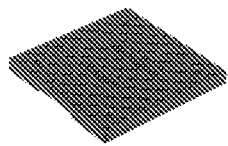

Sealed Access Cover

- For 4D900/901 Bottle Gully
- Complete with sealing ring and screws

Material: PVC-U

Nominal Size (mm)	Part Number	Dimensions (mm) A
-	4D915	217

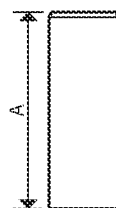
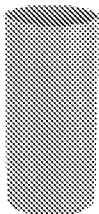

Bottle Gully Riser

- 160mm dia. x 325mm long, for use with 4D900/901 Bottle Gully Range

Material: PVC-U

Nominal Size (mm)	Part Number	Dimensions (mm) A
-	4D916	325

OsmaDrain

Product Details Building Drainage System 110-160mm

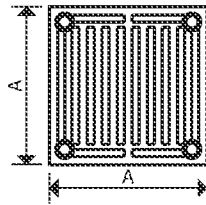
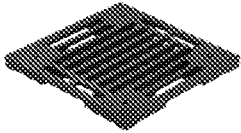

DI Grating

- For 4D900/901 Bottle Gully
- Supplied complete with four fixing screws
- Suitable for installations requiring a loading up to 35kN (3.5 Tonnes), where the frame of the Gully is supported by a concrete plinth

Material: Ductile Iron

Nominal Size (mm)	Part Number	Dimensions (mm) A
-	4D919	217

Yard Gully ~ 300mm dia.

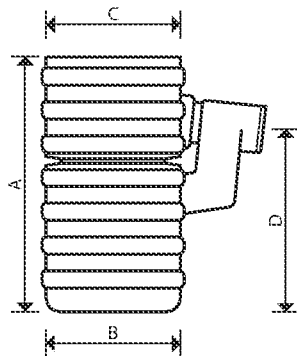
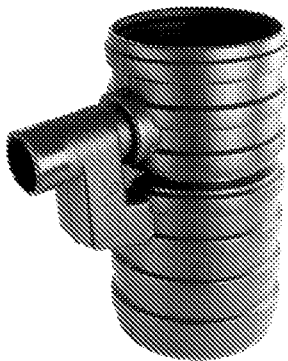

P/E Trapped Yard Gully

- 600mm overall depth, supplied complete with removable rubber bung for rodding access

Material: Polypropylene

Nominal Size (mm)	Part Number	Dimensions (mm)			
		A	B	C	D
110	4D800 ▲	600	305	305	430

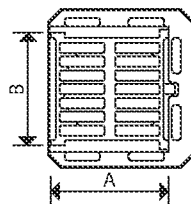
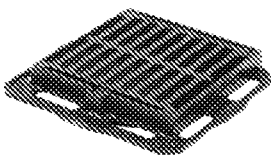

Grating and Frame

- Straight Bar, Hinged
- Suitable for use in installations requiring a BS EN124 – B125 Medium Duty, loading up to 125kN (12.5 Tonnes) where the frame is supported in a concrete plinth

Material: Ductile Iron

Nominal Size (mm)	Part Number	Dimensions (mm)	
		A	B
-	4D810 ▼	303	325

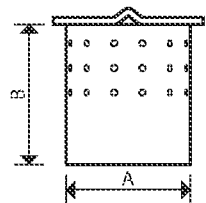
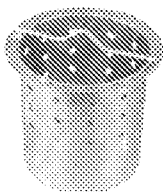

Perforated Catchment Bucket

Material: Galvanized Mild Steel

Nominal Size (mm)	Part Number	Dimensions (mm)	
		A	B
-	4D815 ▲	225	245

Suspended Bracketing System

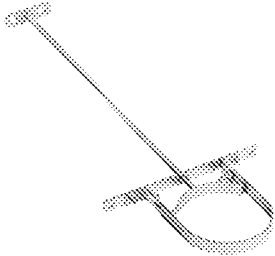

Adjustable Pipe Bracket Assembly

- Pack contains Threaded Rod, Threaded Bracket, Bracket Plate and Pipe/Socket Bracket
- Not suitable for damp inaccessible voids

Material: BZP – Coated Mild Steel

Nominal Size (mm)	Part Number
110	4D086

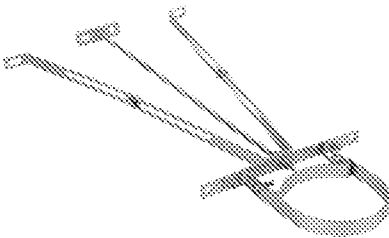

Adjustable Socket Bracket and Brace Assembly

- Pack contains Threaded Rod, Threaded Bracket, Bracket Plate, two Adjustable Braces, and Pipe/Socket Bracket
- Not suitable for damp inaccessible voids

Material: BZP – Coated Mild Steel

Nominal Size (mm)	Part Number
110	4D085

Suspended Bracketing System – Components

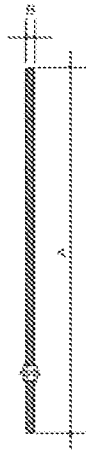

M8 Threaded Rod

Material: BZP – Coated Mild Steel

Nominal Size (mm)	Part Number	Dimensions (mm)	
		A	B
–	–	500	8

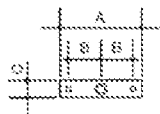

Threaded Bracket

Material: BZP – Coated Mild Steel

Nominal Size (mm)	Part Number	Dimensions (mm)		
		A	B	C
–	–	120	40	30

OsmaDrain

Product Details Building Drainage System 110-160mm

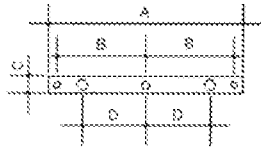
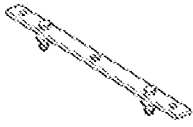

Bracket Pipe

Material: BZP – Coated Mild Steel

Nominal Size (mm)	Part Number	Dimensions (mm)			
		A	B	C	D
–	–	240	110	20	80

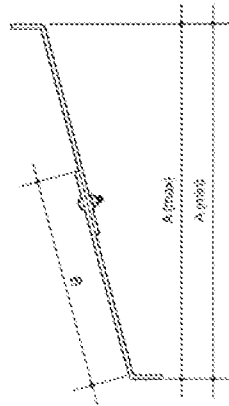
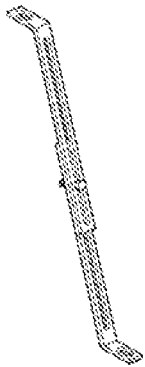

Adjustable Brace

- Used for creating anchor points

Material: BZP – Coated Mild Steel

Nominal Size (mm)	Part Number	Dimensions (mm)		
		A min	A max	B
–	–	264	493	260

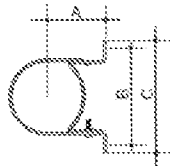

Pipe or Socket Bracket

Material: BZP – Coated Mild Steel

Nominal Size (mm)	Part Number	Dimensions (mm)				Fixing Hole
		A	B	C	D	
110	–	94	160	180	20	7 dia

Testing Equipment

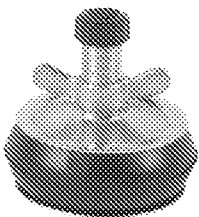

Stopper for Testing

Material: Steel / Rubber

Nominal Size (mm)	Part Number
110	4D998
160	6D998

Cleaners, Solvent Cements, Lubricants



Degreasing Cleaner 250ml

Nominal Size	Part Number
250ml can	4D380



Solvent Cement 125ml

Nominal Size	Part Number
125ml can	4D383 ▼

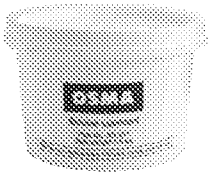

Soluble Lubricant

Nominal Size	Part Number
0.5kg tub	4D391



Soluble Lubricant

Nominal Size	Part Number
2.5kg tub	4D395

Spares – General

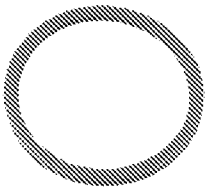

Snap Cap

- 4D116 is combined cap and seal

Material: Polypropylene/TPE

Nominal Size (mm)	Part Number
110	4D116
160	6D116



Ring Seal

Material: TPE

Nominal Size	Part Number
110	4D130

OsmaDrain

Product Details Building Drainage System 110-160mm

Spares – Rodding Eyes



Screws

- New style (Pack of 4)

Nominal Size (mm)	Part Number
–	4D318

Spares – Screwed Access Fittings

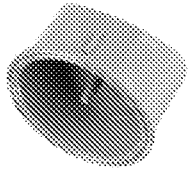

Access Liner

- For 4D593

Material: PVC-U

Nominal Size (mm)	Part Number
–	4D902

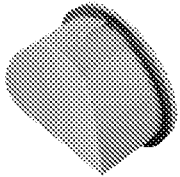

Access Liner

- For Bend

Material: PVC-U

Nominal Size (mm)	Part Number
–	4D909

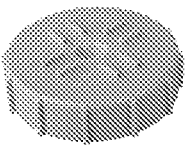

Screwed Access Cap

Material: PVC-U

Nominal Size (mm)	Part Number
–	4D904

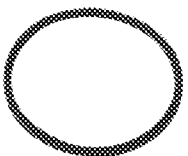

Access Cap Gasket

Nominal Size (mm)	Part Number
–	4D992

Spares – Universal Gully

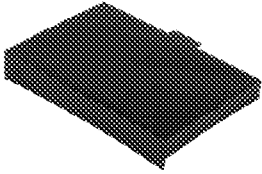

Vertical Inlet Cover

Material: Polypropylene

Nominal Size (mm)	Part Number
–	4D505

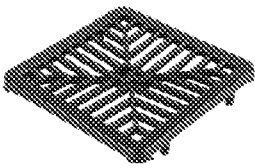

Gully Grating

Material: Polypropylene

Nominal Size (mm)	Part Number
–	4D506 ▲

Spares – 4D900/4D901 Bottle Gullies

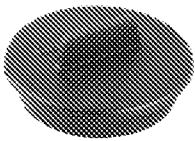

Gully Plug

- New style

Material: Rubber

Nominal Size (mm)	Part Number
–	4D993

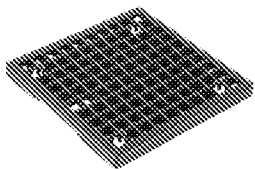

Gully Grating

Material: Polypropylene

Nominal Size (mm)	Part Number
–	4D906

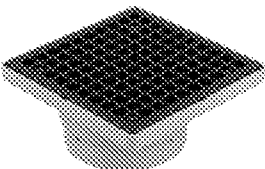

Cover and Frame

Material: PVC-U/Polypropylene

Nominal Size (mm)	Part Number
–	4D908

OsmaDrain

Product Details **Building Drainage System 110-160mm**

Spares – 4D850/4D860 Gullies



Rotating Top and Grid

Material: Polypropylene

Nominal Size (mm)	Part Number
–	4D851

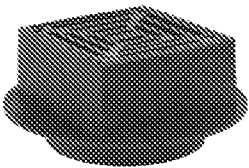

Spare Top

Material: Polypropylene

Nominal Size (mm)	Part Number
–	4D861

Spares – 4D420/4D492

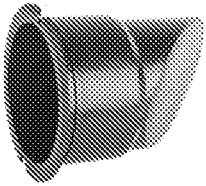

Sealed Inspection Junction Plug

Material: PVC-U

Nominal Size (mm)	Part Number
–	4D494

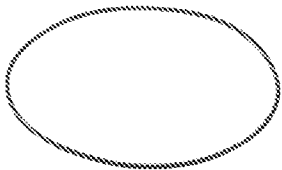

Inspection Junction Gasket

Material: EPDM

Nominal Size (mm)	Part Number
–	4D421



Inspection Junction Cover

Material: PVC-U

Nominal Size (mm)	Part Number
–	4D930

OsmaDrain

Transport, Handling and Storage

Resources and Planning

The main contractor, or sub-contractor, needs no special equipment or power.

Contractors are responsible for checking layout drawings to ensure they are correct so that expensive site alterations do not have to be made after laying.

Contractors may make up OsmaDrain components such as gully assemblies off-site and in clean working conditions – particularly when components have solvent welded joints.

Pipes and fittings made from PVC-U, Polypropylene and/of Polyethylene are lightweight – between one sixth and one tenth the weight of equivalent clay pipes. Nevertheless, care must be taken during transport, handling and storage.

Transport

Block bundles

Generally, pipes are delivered pre-packed in block bundles of standard quantities. In these bundles, pipes are held by straps and timber stretchers.

Figure 1: Loading block bundles on to flat bed vehicle

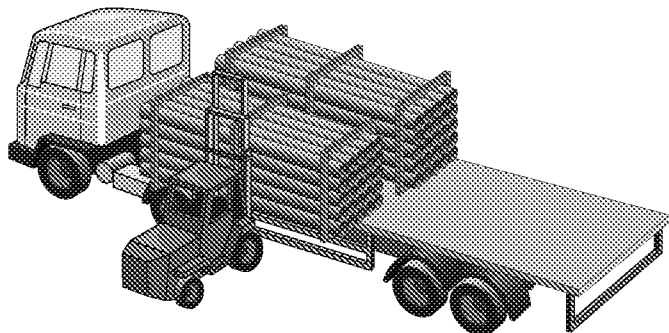

Table 6: Pipe weights

Nominal Size (mm)	Number of 3m/6m lengths per bundle	Dimensions (mm)		Weight per bundle (kg)	
		height	width	3m	6m
110	50	725	1145	250	500
160	25	865	1035	269	538

Loose pipes and fittings

When vehicles with a flat bed are used for transporting loose pipes, make sure the bed is free of nails and other projections.

Support pipes throughout their length. Load pipes so that they do not overhang the vehicle by more than one metre.

Always load pipes with larger diameters and thicker walls before those of smaller diameters and thinner walls. OsmaDrain pipes should always be lifted off the vehicle, not dragged, thus avoiding damage to the pipe ends.

Make sure vehicles have adequate side supports at approximately 2 metre spacings, and that all uprights are flat, with no sharp edges. Secure pipes during transit.

Fittings are supplied in cardboard boxes or plastic bags.

Handling

Always be careful to avoid damage when handling pipe. Cold weather reduces their impact strength, so take extra care when handling pipe in wintry conditions.

When unloading block bundles mechanically, use either nylon belt slings or fork lift trucks with smooth forks. Metal slings, hooks or chains must not come into direct contact with the pipe.

Load and unload loose pipes by hand and avoid using skids. When loose pipes have been transported one inside the other, always remove the inner pipes first.

Do not drop or drag pipes.

OsmaDrain

Transport, Handling and Storage

Storage

Block bundles

Store block bundles on a reasonably flat surface free from sharp projections likely to damage the pipes.

Block bundles can be stored up to three high without extra side supports or bearers. In addition, block bundles will remain free standing when cut.

Take care when removing pipes from bundles as the straps are under considerable tension and may flail when cut.

Loose pipes

Store loose pipes on a reasonably flat surface free of sharp projections. Provide side supports at least every 2 metres. These supports should preferably consist of battens at least 75mm wide (See Figure 2).

Ideally, loose pipes should be uniformly supported throughout their entire length. If this is not possible, place timber supports at least 75mm wide at 1 metre maximum centres beneath the pipes (See Figure 3).

Stack pipes of different size and wall thickness separately. If this is not possible, stack pipes with larger diameters and thicker walls under those with smaller diameters and thinner walls.

Do not stack pipes more than seven layers in height or above a maximum height of 2 metres.

Fittings

Store fittings supplied in plastic bags away from direct sunlight.

If fittings have to be stored outside in their plastic bags, open the bags to prevent a build-up of temperature.

The above storage requirements apply to the United Kingdom climatic conditions. In tropical climates reduce the stack height and store pipes and fittings under cover or in the shade.

Sealing rings

Where applicable, OsmaDrain 110mm and 160mm sockets are supplied complete with a captive ring seal.

Figure 2: Storage of loose pipes on the ground

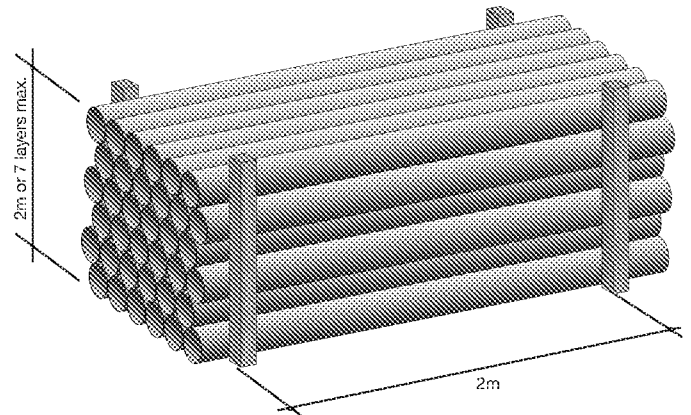
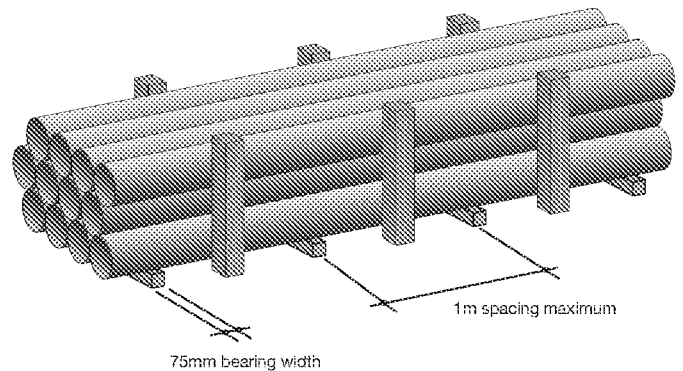

Figure 3: Storage of loose pipes on bearers



OsmaDrain

Installation Requirements

Installation notes

The information included on this page is based on the recommendations given in: BS 8000-14: 1989, BS EN 1610: 1998, BS EN 752: 2008 and British Board of Agreement Certificate: 19/5622.

Bedding and backfill must be of the correct specification. Excavated 'as-dug' material may be suitable. (See BS EN 1610 and BS 8000: Part 14).

Excavation

It is important to take precautions against trench collapse. Do not open trenches too far in advance of pipe laying. Support the sides of trenches that are deeper than 1.2 metres. Keep trench widths as narrow as practicable but not less than 300mm wider than the pipe diameter, i.e. 150mm clear each side of the pipe to allow proper compaction of the sidefill.

Bedding

OsmaDrain pipes laid on trench bottom
Where the 'as-dug' material is suitable*, the bottom of the trench may be trimmed to form the pipe bed (See Figure 4).

*Suitable material is defined as granular material in accordance with the recommendations of BS EN 1610 and BS 8000 -14.

Small depressions should be made to accommodate sockets. After the pipe has been laid these should be filled carefully ensuring that no voids remain under, or around, the sockets.

When the formation is prepared, the pipes should be laid upon it true to line and level within the specified tolerances. Each pipe should be checked and any necessary adjustments to level made by raising or lowering the formation, ensuring that the pipes finally rest evenly on the adjusted formation throughout the length of the barrels. Adjustment should never be made by local packing. When the formation is low and does not provide continuous support, it should be brought up to the correct level by placing and compacting suitable material.

Figure 4: OsmaDrain pipes laid on trench bottom

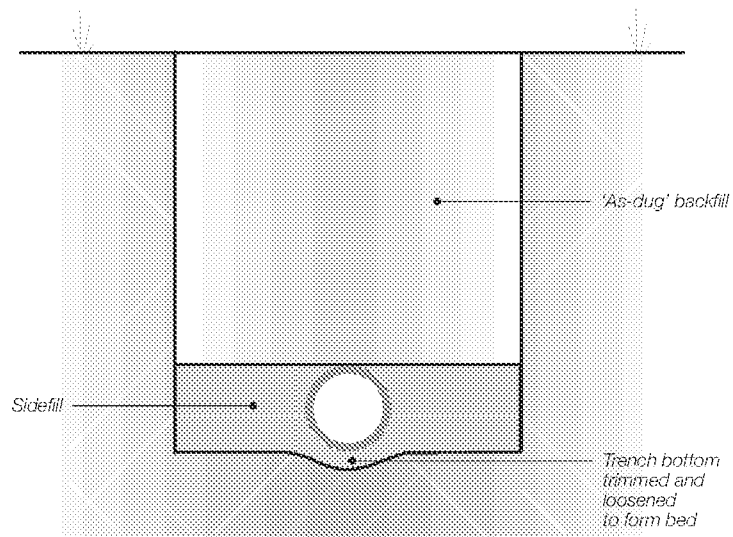

OsmaDrain

Installation Requirements

OsmaDrain pipes laid on a 50mm minimum processed granular bed

Where the as-dug material can be hand trimmed by shovel and is not puddled when walked upon, a 50mm depth of bedding material may be used. In this case the material must be nominal 10mm single sized aggregate with no sharp edges, i.e. pea gravel (See Figure 5).

OsmaDrain pipes laid on a 100mm minimum processed granular bed

When the as-dug material is not suitable as a bedding, a layer of suitable granular material as defined in BS EN 1610:1998, section 5.3.3.1, must be spread evenly on the trimmed trench bottom before the pipes are installed. The trench should be excavated to allow for a minimum thickness of 100mm granular bedding under the pipes (See Figure 6).

The trench formation should be prepared, the bedding placed and the pipes laid in accordance with BS EN 1610:1998 and BS 8000-14:1989.

When the pipes are to be laid on rock, compacted sand or gravel requiring mechanical means of trimming should be used, or in very soft or wet ground, the bedding should be as detailed above.

Figure 5: OsmaDrain pipes laid on 50mm minimum of processed granular material

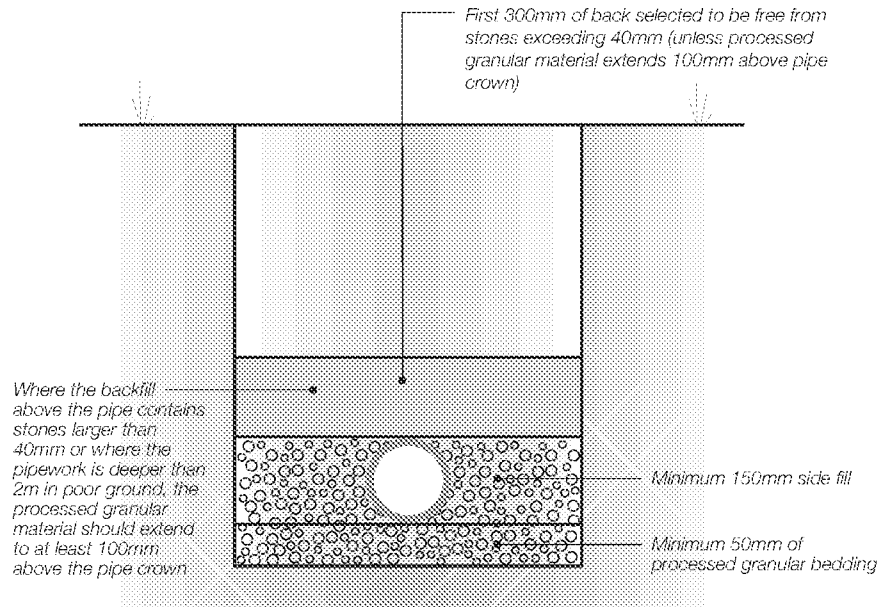
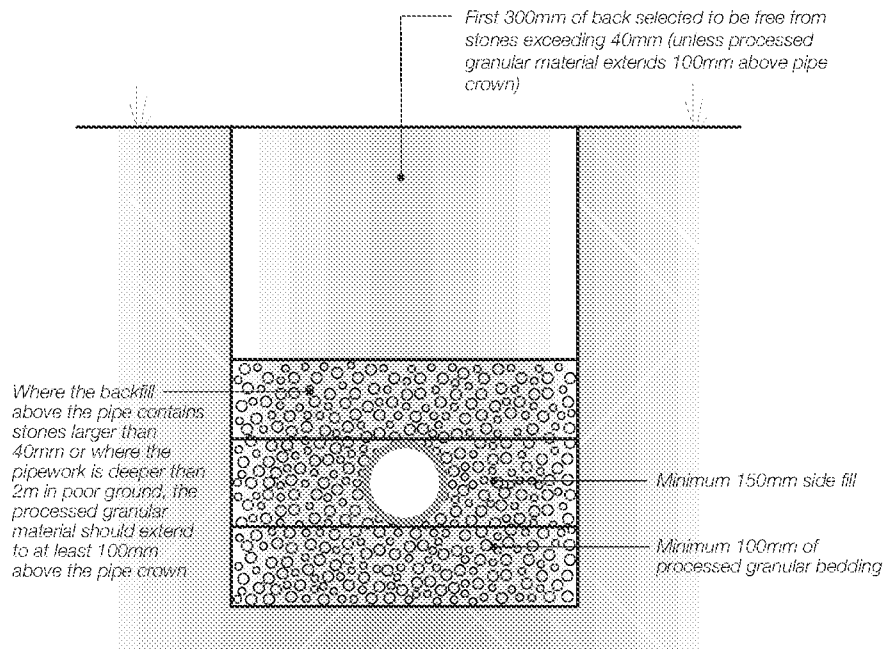

Figure 6: OsmaDrain pipes laid on 100mm minimum of processed granular material



OsmaDrain

Installation

Backfill Sequence

1. Place suitable sidefill material evenly on each side of the pipe in 100mm layers. Pay particular attention to the area under the lower quadrants of the pipe. Hand tamp well at each layer up to the pipe crown. Leave the pipe crown exposed.
2. If 'as-dug' material is free from stones exceeding 40mm, imported processed granular material is not needed above the pipe crown (See Figure 5). Cover the pipe crown with a minimum of 300mm of compacted 'as-dug' material. If 'as-dug' material contains stones larger than 40mm, or the pipe is deeper than 2 metres in poor ground, extend the processed granular material for at least 100mm above the pipe crown.
3. In both cases, hand tamp the material fully at the sides of the pipe while tamping lightly over the crown. Continue hand tamping until a finished layer of 300mm, 225mm in adoptable situations, has been placed over the pipe.
4. 'As-dug' material may be backfilled in 300mm/225mm layers and mechanically tamped. Dumpers or other vehicles must not be driven along the pipe tracks as a means of compacting. Surround vertical or steeply raking pipes with 150mm bedding material, suitably tamped up to the invert level of the incoming pipe (Backdrops) or to ground level.

Pipe Protection

As PVC-U pipes are flexible they can accommodate a degree of ground movement and pressure without damage. However, if the pipe needs protection the following recommendations should be followed:-

Traffic free areas

In areas where no loading is expected (e.g. in gardens) pipes at depths less than 0.6 metre, should, where necessary, be protected against risk of damage from garden implements, for example by placing over them a layer of concrete paving slabs with at least a 75mm layer of suitable material between pipe and slab. (See Figure 7).

Public highways / adoptable situations
In areas where loading is expected, pipes laid at depths less than 0.9 metre below the finished surface of a road, (1.2m in adoptable situations) should be protected with a concrete slab of suitable strength which should bridge the full width of the trench so it sits on the trench wall (See Figure 8). or, alternatively the pipe can be totally surrounded in concrete (See Figure 9).

Concrete of suitable strength or the requirement for reinforced concrete to be determined by the engineer or adopting authority.

The normal maximum depth for all installations is 10 metres.

Figure 7: Pipe Protection in Traffic Free Areas – concrete paving slabs

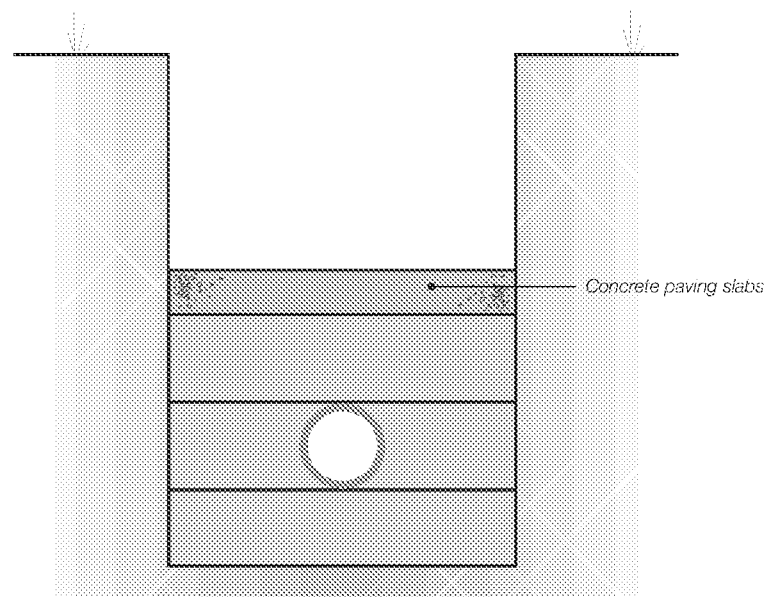

OsmoDrain

Installation

Use of concrete

If pipes are to be surrounded with concrete, make sure they do not float when the concrete is poured. Filling the pipes with water will generally provide enough ballast but side restraint may be needed to maintain alignment.

To maintain a certain degree of flexibility, insert 18mm compressible material, such as fibreboard or polystyrene, around the pipe joints (See Figure 9). These boards must be at least the width of the concrete surrounds.

Pipes under buildings

A drain may run under a building if at least 100mm of granular or other flexible filling is provided round the pipe. On sites where excessive subsidence is possible additional flexible joints may be advisable or other solutions such as suspended drainage. Where ground settlement is expected and the crown of the pipe is within 300mm of the underside of the slab, concrete encasement should be used integral with the slab (see The Building Regulations 2013, H1 para 2.23)

Pipes penetrating walls

Where a short length of pipe is to be built into a structure, a suitable wall protection sleeve should be used. The short length of pipe should then be inserted through the wall protection sleeve, and fixed with couplers placed either side within 150mm from the wall face. The length of the next 'rocker' pipe should not exceed 0.6 metre. This will compensate for any settlement of the building or made up ground.

Alternatively, where it is not necessary for a pipe to be built into a structure, the provision of a lintel, relieving arch or sleeve may be used, leaving a gap of not less than 50mm around the pipe. Effective means should be adopted to prevent the entry of gravel, rodents or gases.

Figure 8: Pipe Protection – concrete slab

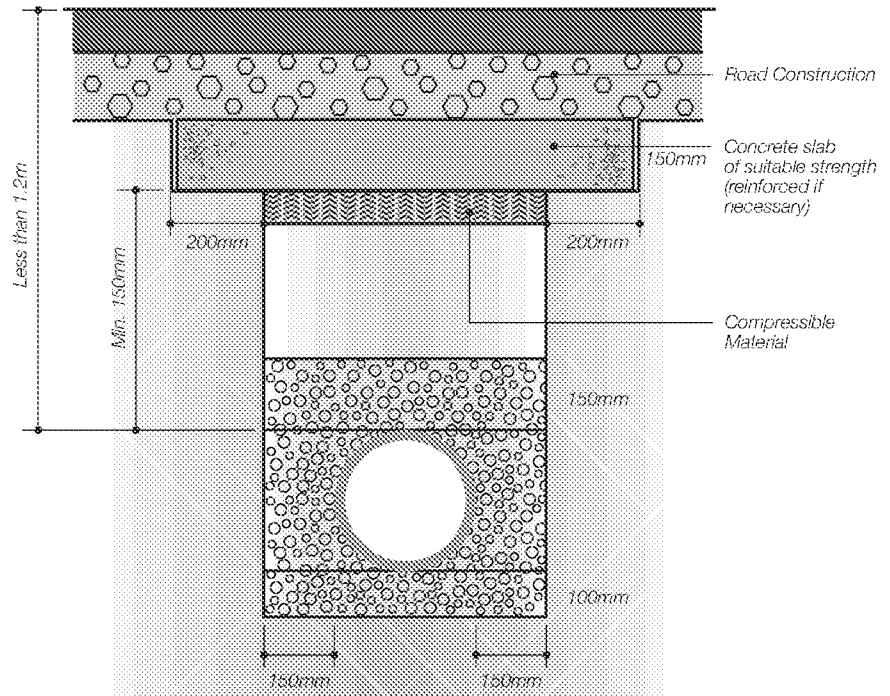
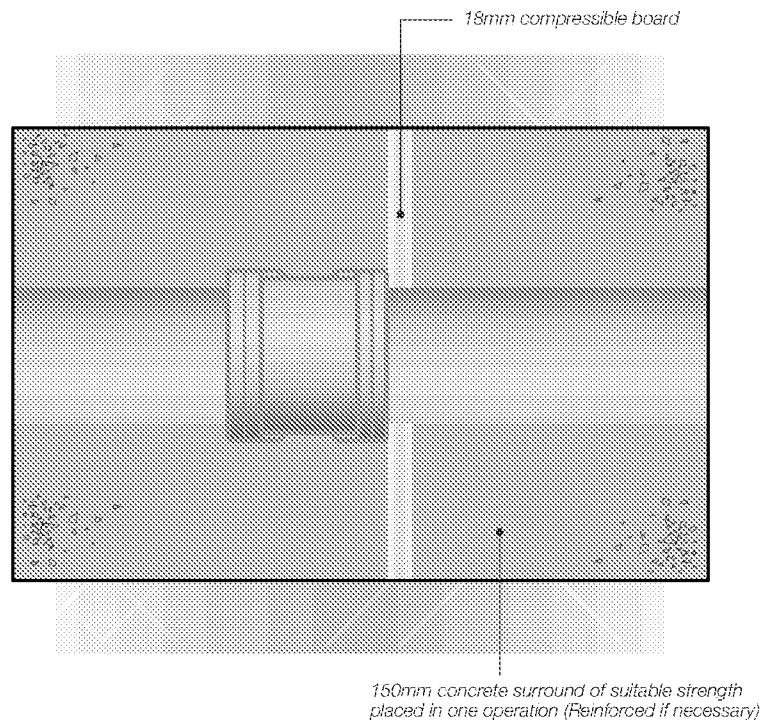

Figure 9: Pipe Protection – concrete surround



Joining

Preparing Pipe Ends

Pipes cut on site must be clean cut at right angles to their horizontal axis. Deburr the cut end with a scraper.

Depth of Entry Mark

Some plain ended fittings have a depth of entry mark moulded on the spigot. This depth of entry allows the pipe to expand into the fitting socket by a minimum of 12mm. Insert the spigot into the socket until the depth of entry mark is just visible.

All pipes (whether site cut or otherwise) and other plain ended fittings must be inserted to the full depth of the socket, marked at the socket face, and then withdrawn at least 12mm (See Figure 10).

Ring Seal Joints

Pipe couplers and most bends and junctions (in both 110mm and 160mm sizes) are supplied with sockets on all ends. These sockets are fitted with ring seals which act as both a sealing and expansion joint.

The correct sequence for ring seal jointing is as follows:

1. Check that the pipe is correctly prepared (See Pipe preparation, Figure 11a) and that the ring seal is properly seated in its housing.
2. Make sure that both the pipe or fitting spigot and ring seal socket are dry, clean and free from grit or dust.
3. Lubricate evenly around the spigot (NOT the socket) with OsmaDrain Lubricant (4D392) (See Table 7).
4. Make sure that the components to be joined are correctly aligned.

5. Push the spigot fully into the socket. Mark the spigot at the socket face and then withdraw the spigot by a minimum of 12mm. If the spigot is already marked with the depth of entry, push it into the socket until the depth of entry mark is just visible.
6. Do not cut back the straight leg sections of Long Radius Bends (4D/6D281) as only the spigot end provided is suitable for jointing.

Table 7: Lubricant allowance (for guidance only) weights

Nominal Size (mm)	Approximate No. of joints (per 100g)
110	100
160	45

Figure 10: Ring Seal jointing

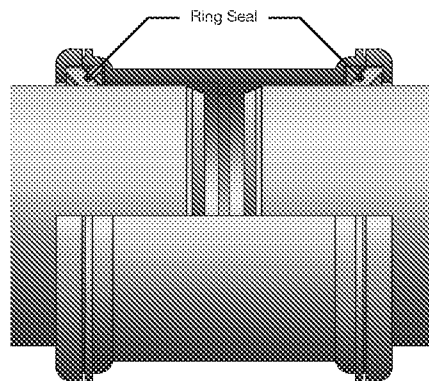

Figure 11a: Pipe preparation

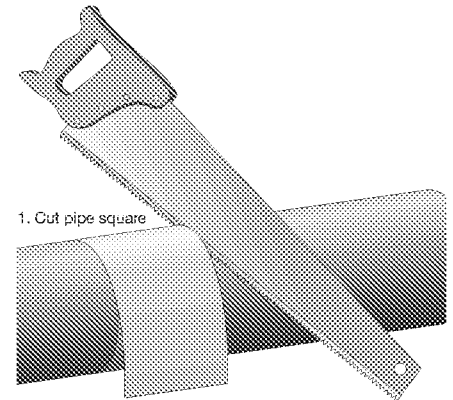
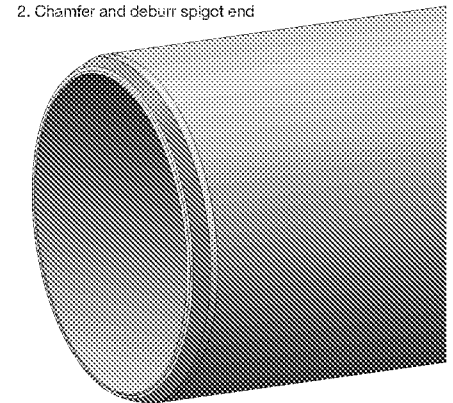

Figure 11b: Pipe end

2. Chamfer and deburr spigot end



OsmaDrain

Installation

Solvent Weld Joints

There are relatively few fittings which need to be solvent jointed. The correct sequence for solvent jointing is as follows (also see Figure 12):

1. Ensure that the pipe has been cut cleanly and at right angles to its axis.
2. Clean swarf and other dirt from the pipe end.
3. Wipe the inside of the socket and the spigot of the pipe or fitting to remove any surface dirt.
4. To remove grease and prepare the surfaces of the socket and spigot, clean both surfaces with Osma Degreasing Cleaner No 1 (4D380) applied liberally on a clean nonsynthetic rag or absorbent paper.

5. Apply one coat of Solvent Cement No 2 (4D383) evenly, using a clean brush, to both the mating surfaces, stroking the cement along and not around the surfaces.
6. Immediately insert the spigot straight into the socket until the full socket depth is reached, hold for 20–30 seconds and remove any surplus cement from the mouth of the socket.
7. Each solvent joint must be completed within 1½ minutes.
8. The joint may be handled after 10 minutes and commissioned after 24 hours.

Do not thin Solvent Cement or Solvent Cement Filler. As these cements are solvent based it is essential to observe the normal precautions for solvents (see 'Safety' page 54).

Boss Socket Connections

These may be made on the top of sealed inspection junction covers using either a 32mm or 40mm Boss Socket Adaptor (4S398/399).

Make the connection by drilling out the unperforated boss socket on the fitting using a standard 54mm hole cutter. Solvent weld as described in 'Solvent Weld Joints', pushing the adaptor the full depth along the keyway of the boss socket.

Table 8: Solvent cement allowance

Nominal Size (mm)	Approximate No. of joints (per 500g)
110	44
160	24

Figure 12: Solvent Welding – OsmaDrain Bottle Gully to Pipe spigot

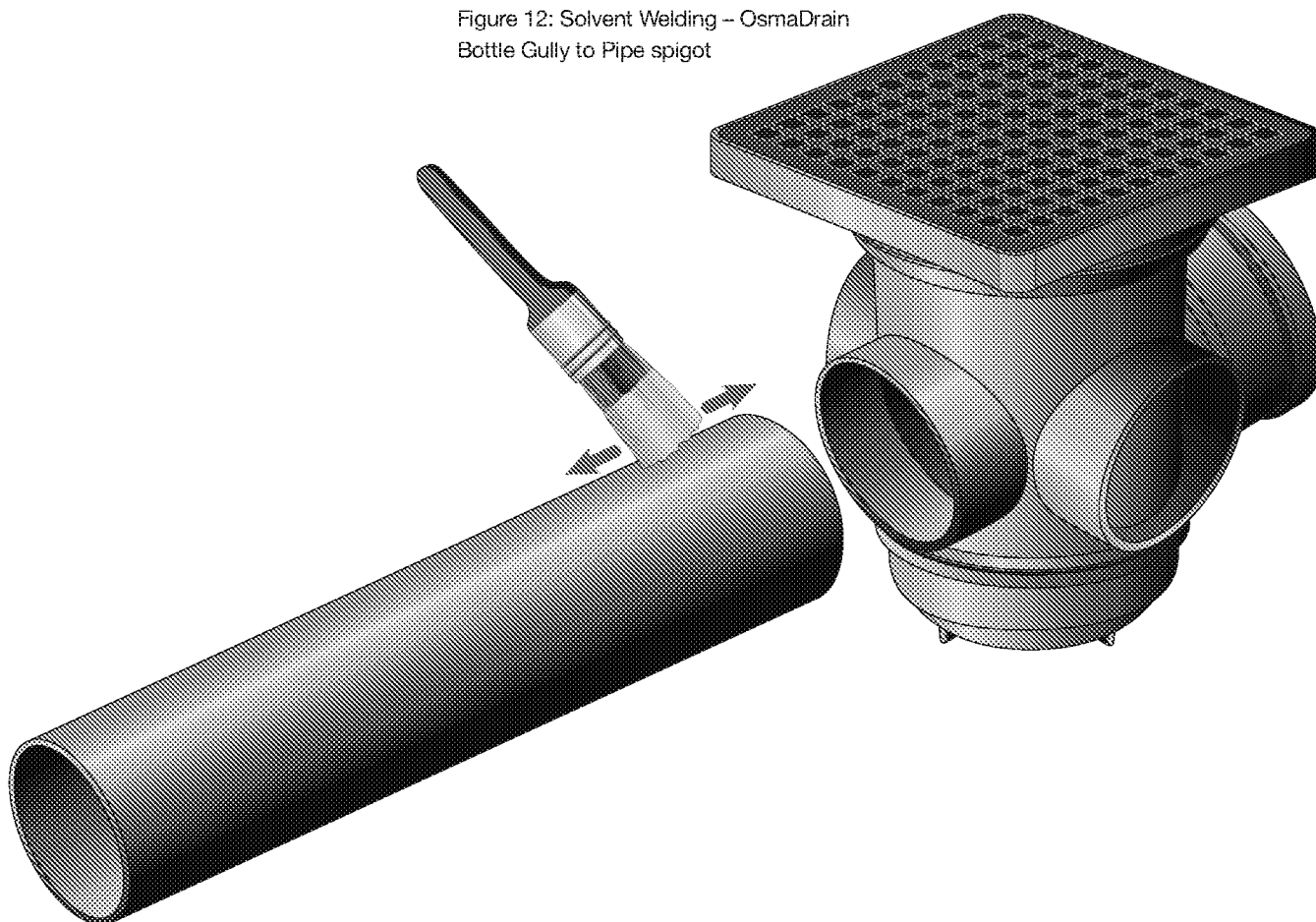

Vertical Connections

Connection of internal Waste Pipe

Fit a small off-cut of 110mm pipe into the socket of the Short Radius Bend (4D561) so it ends up flush with the top of the socket 4D561. Insert the 32/40mm (4D298) or 50mm (4D299) waste pipe in to the connector, working the pipe through the opening.

Alternatively, for deep applications install the Connector (4D298/299) directly into the spigoted end of a 110mm pipe, (See Figure 14).

Connection of internal Rainwater/Soil/Waste Pipe

To connect internal 110mm PVC-U soil pipe to a drain, push the pipe spigot into the socket of a Long Radius Bend (4D581) (See Figure 15). Alternatively, to connect 110mm PVC-U rainwater pipe to a drain, push the pipe spigot into the socket of a Short Radius Bend (4D561).

To connect 82mm rainwater or soil pipe to drain, fit a 110mm x 82mm Reducer (4D095) to the socket of a Short Radius Bend (4D561). When installing either Long or Short Radius Bends at a deeper level, fit a Coupler (4D205) and a short length of pipe to the installation. (See Figure 16).

Connection of external Osma RoundLine Rainwater Pipe

Fit an Adaptor (4D149) over the spigot of a short length of OsmaDrain pipe. Fit the other end of the pipe into a socket of a Short Radius Bend (4D561). Fit the end of the 68mm RoundLine Rainwater Pipe into the plain socket of the Adaptor. Neither lubrication nor solvent welding is necessary (See Figure 17). Alternatively, fit an Adaptor (4D149) over a Coupler (4D205) and connect the Coupler to the short length of drainpipe. Complete the installation as above. For a shallow installation fit the Adaptor (4D149) over the socket of a Short Radius Bend (4D561) (See Figure 18).

Figure 13: Connection of internal waste pipe

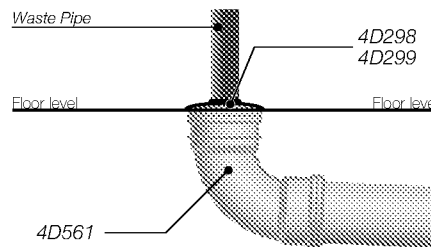

Figure 14: Connection of internal waste pipe at depth

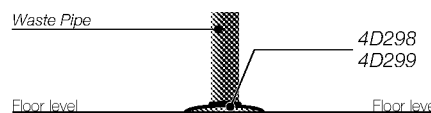

Figure 15: Internal connection of 110mm diameter soil pipe

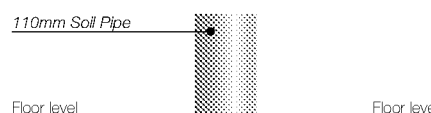

Figure 16: Internal connection of 82mm diameter rainwater or waste pipe



Figure 16: Internal connection of 82mm diameter rainwater or waste pipe

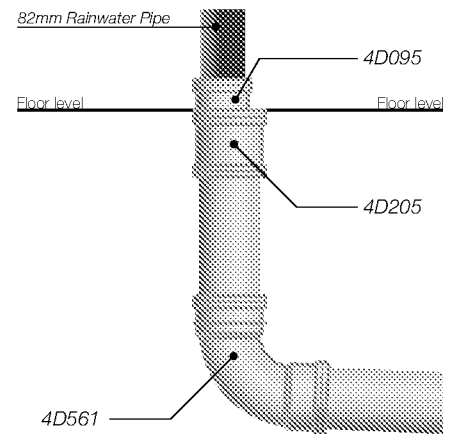

Figure 17: Connection of RoundLine rainwater pipe to OsmaDrain 110mm spigot

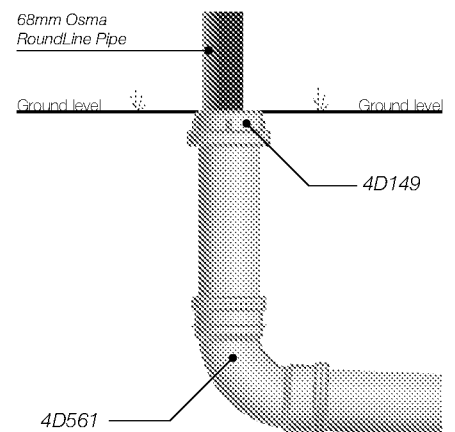
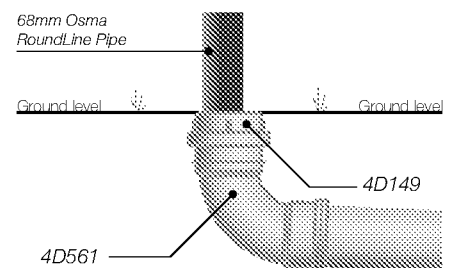

Figure 18: Connection of RoundLine rainwater pipe to OsmaDrain 110mm socket



OsmaDrain

Installation

Connection of external Osma round and square profile Rainwater Pipe

The Universal Drain Adaptor (4D159) can be used in many types of applications, ie for connecting both circular and square profiled rainwater pipes up to 70mm and a minimum 60mm round rainwater down pipe.

However it is recommended that the Adaptor is only used in external situations.

Installation of Universal Drain Adaptor

Connection to a 110mm OsmaDrain Spigot.

1. Check that the pipe has a straight edge and is free from swarf.
2. Fit the Adaptor over the spigot ensuring that both lips are located on the outside of the pipe spigot (See Figure 19a).

Connection to a 110mm OsmaDrain Socket.

1. Remove the snap cap and sealing ring from the socketed component.
2. Turn the Adaptor inside out (See Figure 19b).
3. Fit the Adaptor, ensuring that the outer lip is located on the outside of the socket, with the inner lip located within the socket itself (See Figure 19c).

Connection of Osma RoundLine Rainwater Pipe

1. Ensure that the Osma RoundLine Pipe is free from swarf.
2. Place the pipe into the Adaptor, working the pipe through the opening until the pipe is located in the Adaptor to a suitable depth (See Figure 20).
3. Fix a rainwater bracket no more than 150mm from the Adaptor.

Connection to SquareLine Rainwater Pipe

1. Firstly, using the cutting guides, (located on the underside of the Adaptor) cut the Adaptor to the required size.
2. Fit the Adaptor to either an OsmaDrain spigot or socket as detailed.
3. Ensure that the SquareLine rainwater pipe is free from swarf.
4. Place the pipe into the Adaptor, working the pipe through the opening, until the pipe is located in the Adaptor to a suitable depth (See Figure 21).
5. Fix a suitable rainwater bracket no more than 150mm from the Adaptor.

Figure 19a: Connection to a 110mm OsmaDrain spigot

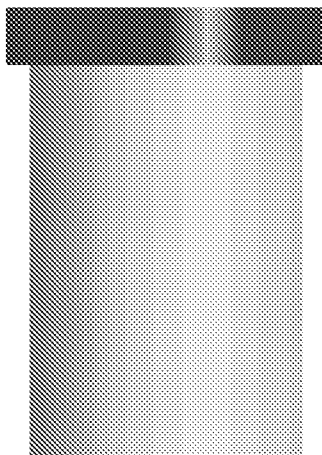

Figure 19b: Adaptor turned inside out

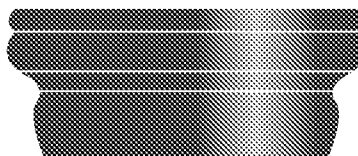

Figure 19c: Connection to a 110mm OsmaDrain socket

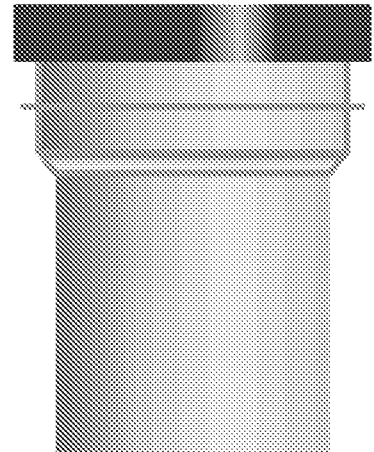

Figure 20: Connection of Osma RoundLine Rainwater Pipe

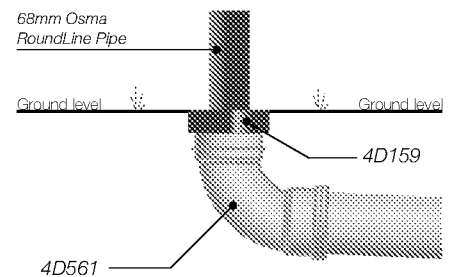
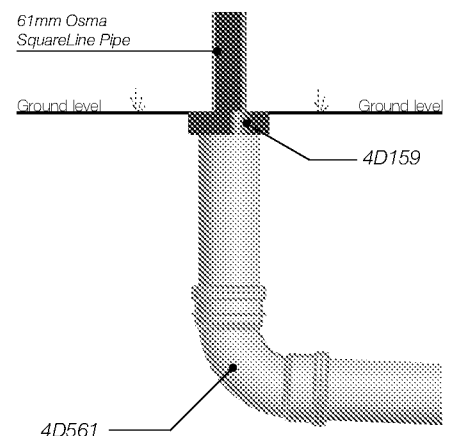

Figure 21: Connection of SquareLine Rainwater Pipes



Backdrop Connections

A backdrop to a manhole is a method of connecting two substantially different drain line invert levels in a manhole. This can be done either internally or externally by using the following 110mm or equivalent 160mm fittings, as follows.

Installation of backdrops

1. For an internal backdrop, use a Socket Plug (4D296) or a Screwed Access Cover (4D292), plus an Equal Access Junction (4D593), vertical pipe to suit, a Short Radius Bend (4D161) or a Sealed Access Fitting to suit (See Figures 22).
2. Fix internal vertical pipe securely to the manhole wall with OsmaSoil Brackets (4S083).
3. For an external backdrop, use an 87.5° Equal Junction (4D193), vertical pipe to suit and either a Long Radius Bend (4D581), or a Short Radius Bend (4D561), (See Figure 23). (For bedding of vertical pipes see 'Backfill Sequence' page 38).
4. Alternatively, ramped backdrops can be used, for drops of less than 1.8 metres, by means of two 45° Bends (4D563/163) and a raking length of pipe.

Figure 22: Sealed Access Manhole with internal backdrop

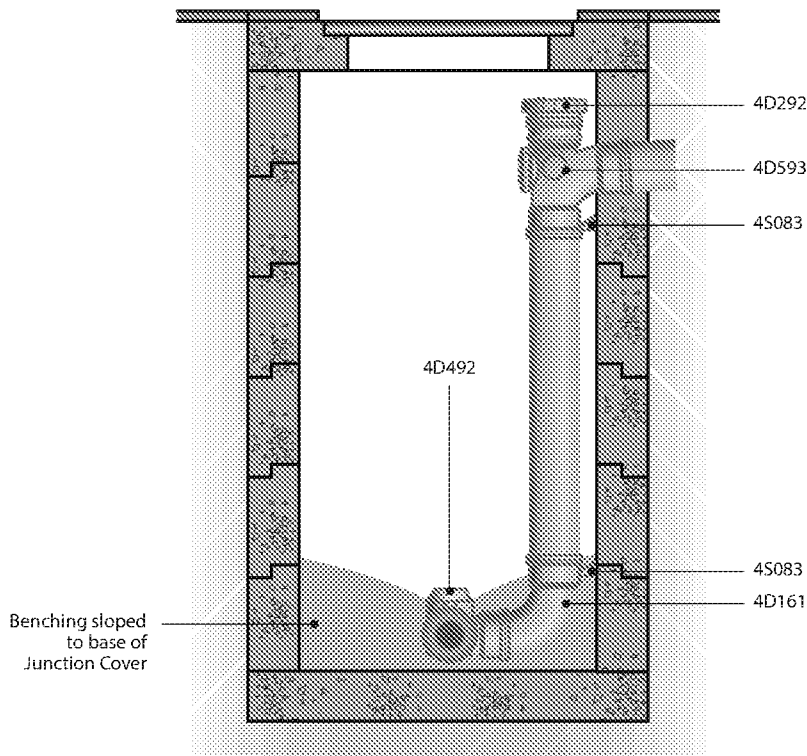
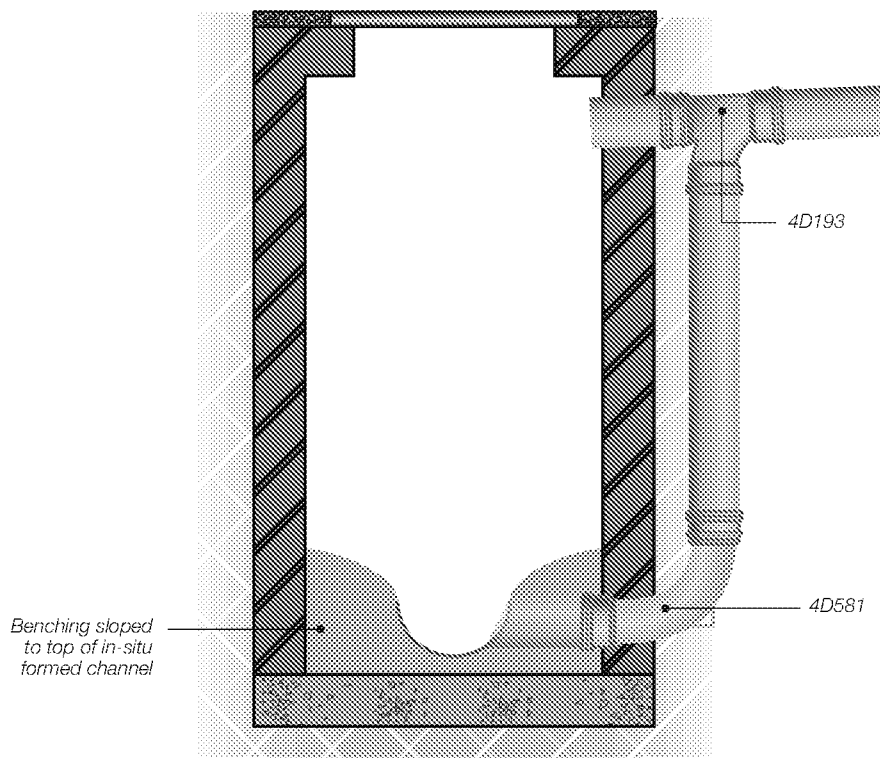

Figure 23: Open Channel Manhole with stepped invert and external backdrop



OsmaDrain

Installation

Sealed Access Fittings

Installation of Sealed Access Fittings

Manholes with Sealed Access Fittings are generally constructed in the same way as traditional manholes but as watertightness is not critical, unlined brick or concrete manholes may be permitted. Benching of the pipework is essential.

1. Bed all Sealed Access Fittings in cement mortar on a suitable concrete base.
2. Make pipe connections in the same way as the standard ring seal jointing of fittings (see Ring Seal Jointing, page 40).
3. Allow pipe ends to protrude beyond the edge of the manhole base so that connections can be made after the manhole walls have been built.
4. Slope benching of the pipework so that standing water will drain into the Access Fitting when the bolted cover is opened. The benching must provide adequate clearance for the access cover to be removed, for routine servicing. Bolts should be tightened in a diagonal sequence. Undue force should not be used during the tightening process.
5. Where standpipes are specified, fit these to the boss socket on the top of the bolted cover (see Boss Socket Connections, page 41 and Figure 24).
6. Use Sealed Access Fittings inside buildings in manholes with single seal manhole covers.

Figure 24: Sealed Access Manhole and standpipe

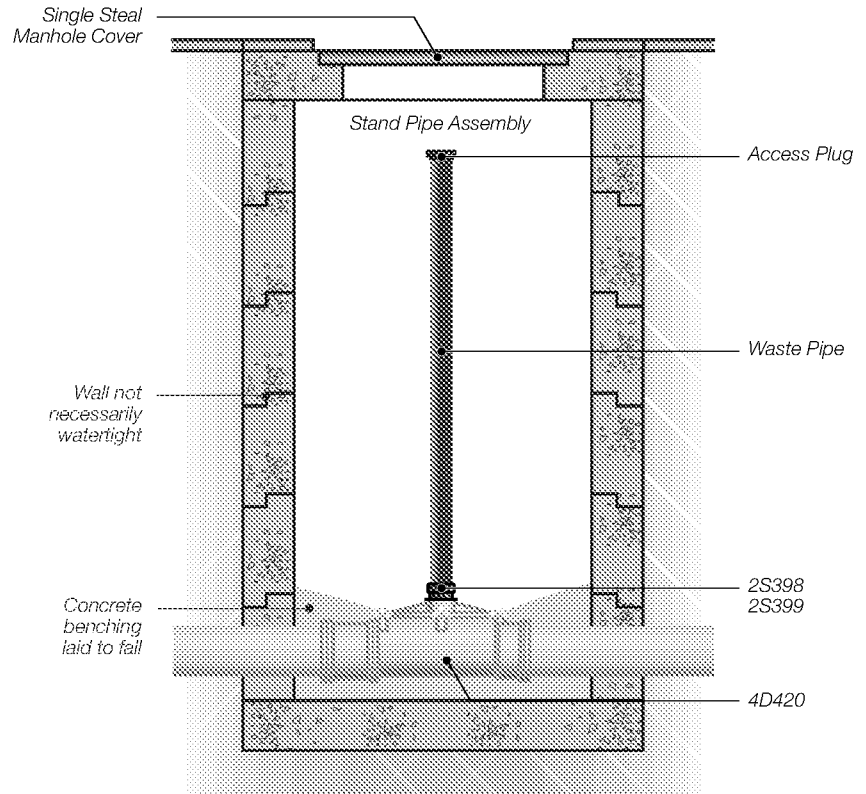

Sealed Rodding Access Fittings

Installation of (4D361), 110/160 straight vertical alternatives are available (4D/6D360)

NOTE: The following Rodding Eye installations comprise of a Rodding Eye (4D360/361) a raking length of pipe and either one or two 45° Bends (see Figures 25 and 26).

Obtain intermediate rodding access by placing the Sealed Rodding Access Eye (4D361) at ground level and connecting it via a raking length of pipe and a 45° Bend (4D163) to a 45° Junction (4D213) on the main drain (See Figure 26). Alternatively use a S/S 45° Rodding Eye (4D361) at ground level and connect it via a raking length of pipe to a 45° D/S Bend at the head of the drain run.

Wherever rodding access points are installed, access must also be provided both inside the house and at the gully. Internally, fit an Osma Access Pipe (4S274) near the base of the soil stack as appropriate. In addition, if the ground floor wc connects direct to drain, fit a WC Connector with access.

Outside the house, provide direct access to the drain through either, the OsmaDrain Bottle Gully (4D860/900/901) or through an Access Bend (4D169/569) fitted to the outlet of the Universal Gully (4D500) (see also pages 47 and 48).

110mm Rodding Eyes can be used for access to larger diameter drains by fitting the appropriate Reducer at the terminal connection. Rodding Eyes should be set in or next to paved areas to make rodding easier.

Figure 25: Rodding Eye – head of drain access

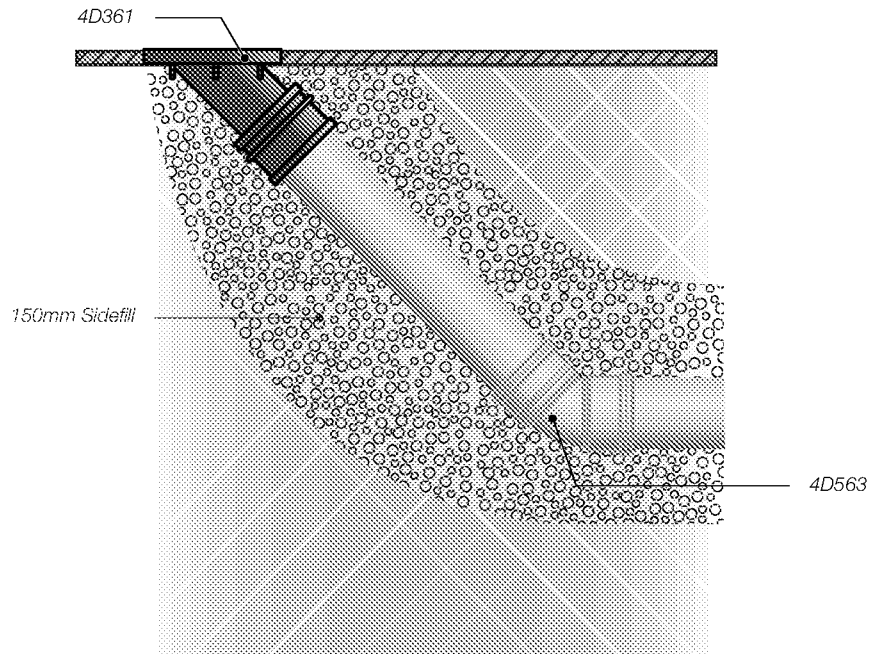
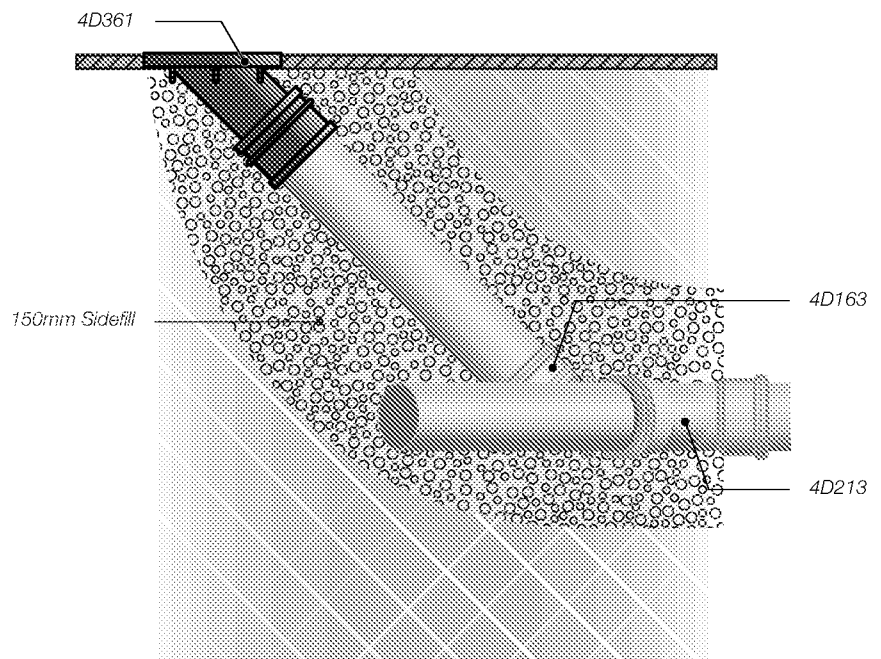

Figure 26: Rodding Eye – intermediate access



OsmaDrain

Installation

Universal Gully

Installation of Universal Gully

1. Assemble the Universal Gully out of the ground.
2. Set it on a substantial base such as a precast concrete slab, bricks or in-situ concrete and haunch it with concrete up to the level where the supporting feet meet the body. Make sure the concrete does not enter any ring seal joints.
3. Make connections to drain with a 87.5° Bend (4D561) or, if access is required, an 87.5° Access Bend (4D569) (See Figure 27).
4. Make vertical inlet connections in accordance with BS EN 12056-3-2000-7.6.9, which states that a branch pipe should only discharge to a gully between the grating and the top level of the water seal. Use an appropriate saw or hole cutter to make a hole of a suitable size in the vertical inlet cover to allow pipe up to 75mm in diameter to be inserted (See Figure 27).
5. Backfill with suitable material.
6. Where a Cast Iron Cover Access Point is required, set it in concrete over the access point (See Figure 27).
7. The sealed Access Hopper (4D527) can be used in areas where foot traffic only is expected.
8. When not protected by paving or concrete at ground level, the crown of the outlet bend must be below the level to which garden implements penetrate, when this is not possible, bed a concrete slab above the bend (See Figure 28).

Figure 27: Universal Gully with vertical inlet and access

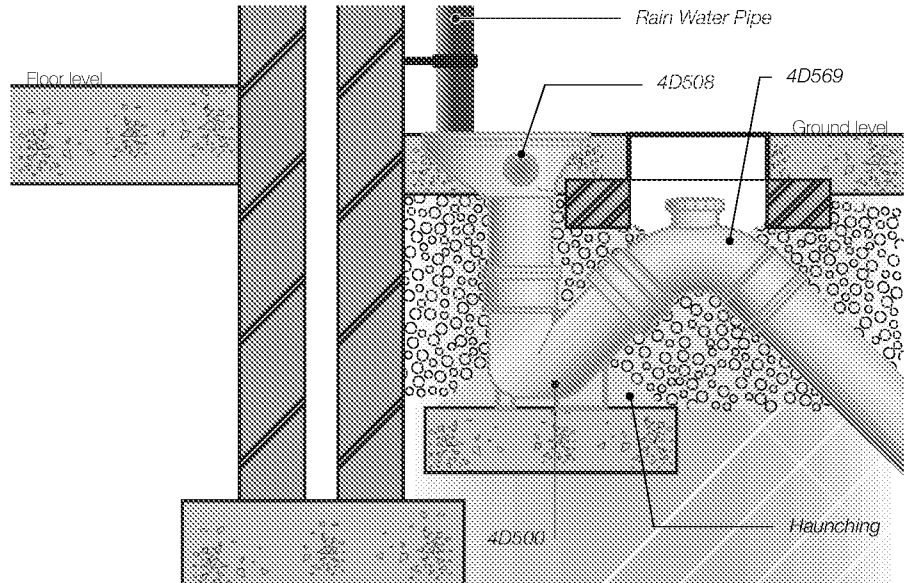
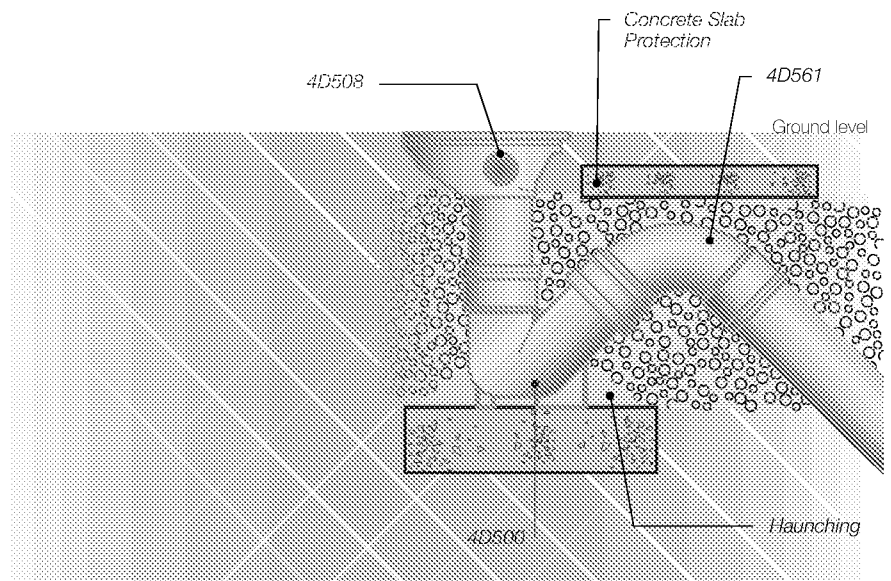

Figure 28: Universal Gully – protection of outlet bend



Bottle Gullies

Installation of 4D850/900 Bottle Gullies

1. Position and level the Gully on a suitable base, such as a pre-cast concrete slab, bricks or in-situ concrete.
2. Haunch it with concrete 25 – 30mm from the base, This will ensure that the base is firmly located.
3. Make any 110mm horizontal connections to either the left, right or back sockets (See Figure 29).
4. Make vertical connections for waste or rainwater pipes by cutting the grating to the necessary diameter and insert the pipe (See Figure 30).

4D900 Gully only

5. To accommodate unpredictable site conditions the 4D900 Gully offers a height adjustment facility. Simply remove the cover and frame from the Gully body. Cut the required length of OsmaDrain 160mm pipe and insert into Gully or alternatively use 4D916 bottle gully riser. Solvent weld cover and frame into pipe end.
6. Backfill the 4D850/4D900 with suitable material. It is not necessary to surround the Gully with concrete.
7. If the 4D900 Gully is to be used internally, a Sealed Access Cover (4D915) is available as an extra. Simply remove the existing grating and by means of four self-tapping screws fix the Access Cover. Full detailed fixing instructions are available with each Sealed Access Cover.
8. If the gully is to be used in areas where light vehicles have access (up to 3.5 tonnes), a Ductile Iron Grating (4D919) is available as an extra. The gully should be surrounded with concrete 150mm deep. The Grating is secured by simply removing the existing grating and by means of four self tapping screws, fix the new grating. Full detailed fixing instructions are available with each Ductile Iron Grating.

Figure 29: Bottle Gully installation with horizontal inlet

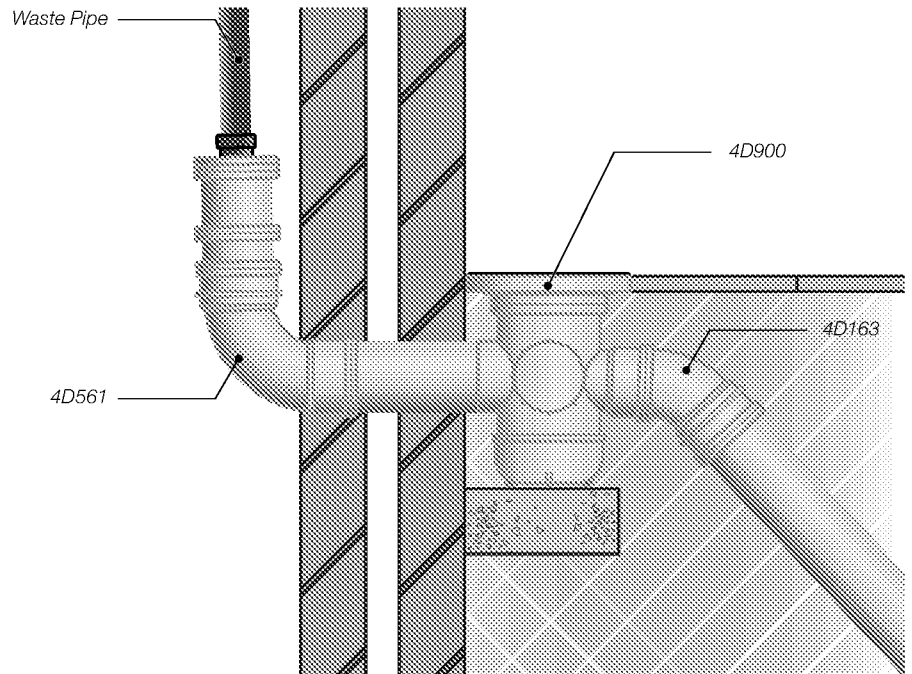
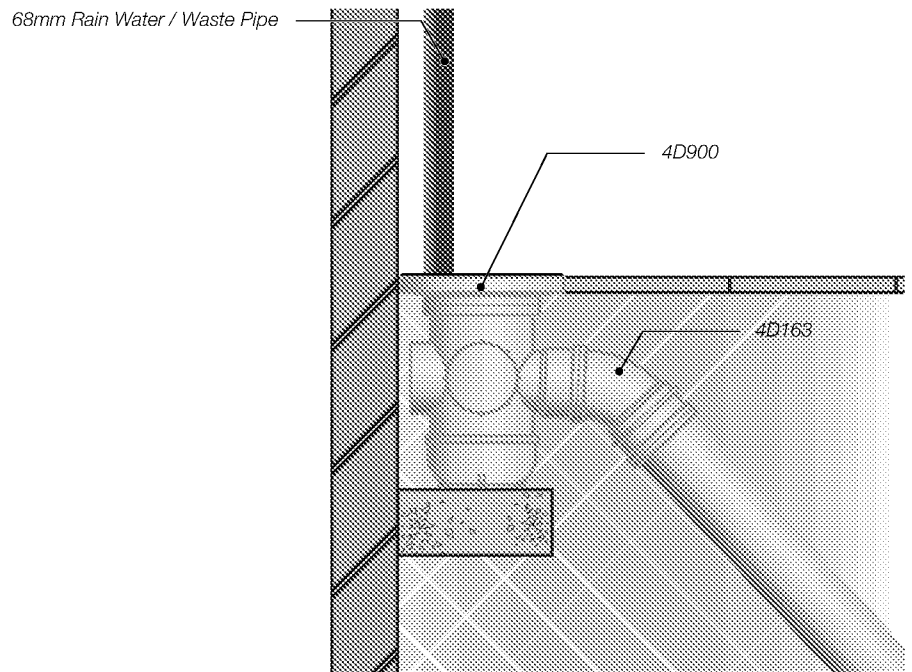

Figure 30: Bottle Gully installation with vertical inlet



OsmaDrain

Installation

Paved Area Gully – 4D860

The OsmaDrain Paved Area Gully (4D860) is a neat, compact and practical alternative to the more traditional gully. The unit comes complete with its own removable dip-tube; trap facility which when removed allows ease of access for rodding and the removal of debris.

The Gully (4D860) is ideal for use in either new or replacement installations and provides the facility for a direct 110mm connection via its back boss. The Gully comes complete with a square cover and frame which is ideal suited for use with either paving slabs or block paving.

Gully Connection – 110mm OsmaDrain

1. Make sure that the ring seal socketed outlet of the Gully and the 110mm OsmaDrain pipe spigot which is to be connected are dry and clean from grit and dust.
2. Lubricate evenly around the pipe spigot (NOT SOCKET) with OsmaDrain Lubricant (4D395).
3. Make sure the components to be joined are correctly aligned.
4. Push the pipe spigot fully into the socket of the Gully.

Installation of Paved Area Gully

1. When excavating the Gully pit allow an additional 100mm under the unit and 150mm around the unit.
2. Sit the Gully (4D860) on a minimum 100mm bed of suitable concrete surround it with similar material 150mm wide, up to the underside of its 110mm socketed outlet. (See Figure 31).
3. Connect the Gully to the branch drain in the appropriate way.
4. Pour concrete around the Gully until it is 20mm above the flange running around the square cover and frame (See Figure 31).
5. Bed either paving slabs or block paving around the cover and frame upto the top of the cover as appropriate (See Figure 31).

Figure 31: Paved Area Gully installation

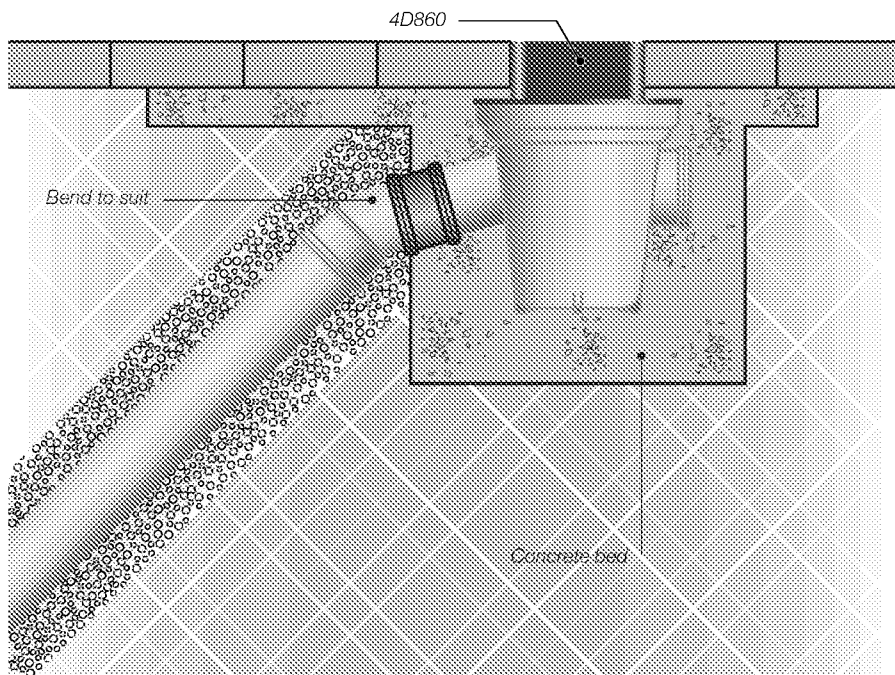

Yard Gully

The OsmaDrain Yard Gully (4D800) comes complete with its own trap facility which allows ease of rodding via a removable rubber plug.

Also available as optional extras are a Perforated Galvanised, Mild Steel Catchment Bucket (4D815) and a Ductile Iron Grating and Frame, suitable for use in installations requiring a BS EN 124-B125 Medium Duty Loading.

Gully Connection ~ 110mm OsmaDrain

1. Make sure that both the Gully spigot and ring seal socket are dry and clean from grit and dust.
2. Lubricate evenly around the gully spigot (NOT SOCKET) with OsmaDrain Lubricant (4D395).
3. Make sure the components to be jointed are correctly aligned.
4. Push the socket fully on to the spigot.

Installation of Yard Gully

1. When excavating the Gully pit allow an additional 100mm under the unit and 150mm around the unit.
2. Sit the Gully (4D800) on a minimum 100mm bed of suitable "as-dug" or granular material and surround it with similar material 150mm wide, up to the underside of its 110mm spigoted outlet, (See Figures 32 and 33).
3. Connect the Gully to the branch drain in the appropriate way.
4. Pour 150mm x 250mm invert of concrete around the Gully up to its lip (See Figures 32 and 33).
5. Where required insert the Galvanised, Mild Steel, Catchment Bucket (4D815). (See Figures 32).
6. Bed the Cast-Iron Grating and Frame in a suitable concrete mix (See Figures 32 and 33).

Figure 32: Yard Gully installation

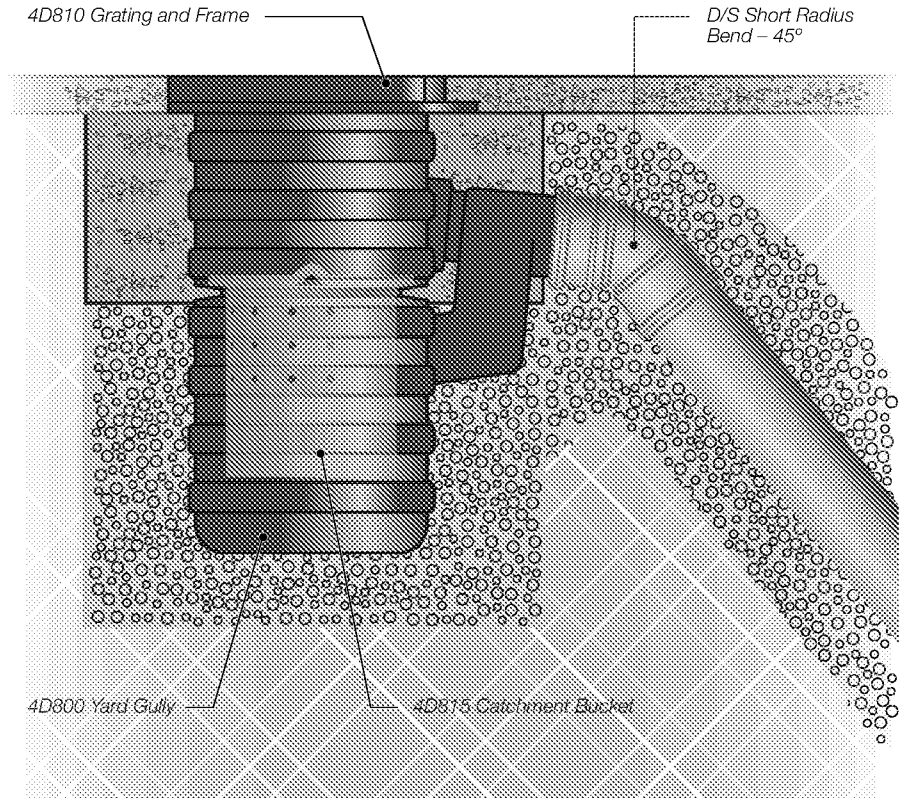
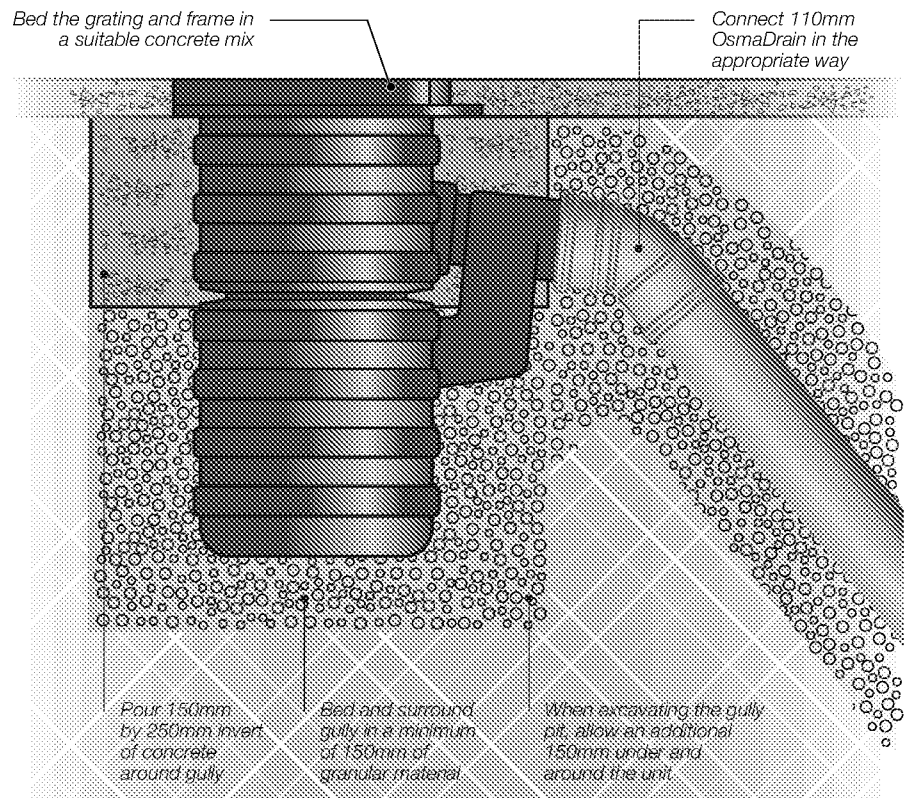

Figure 33: Yard Gully installation



OsmaDrain

Installation

Connections to Other Materials

PVC-U Connection to Thin-wall Clay Spigot

Lubricate spigot of clay pipe and fit a PVC-U Adaptor (4D/6D129). Insert the PVC-U pipe spigot in the standard way (See Figure 34).

PVC-U Connection to Thick-wall Clay Spigot

Lubricate spigot of clay pipe and fit an Adaptor (4D/6D127). Insert the PVC-U pipe spigot in the standard way (See Figure 35).

Figure 34: Connection to thin-wall clay spigot

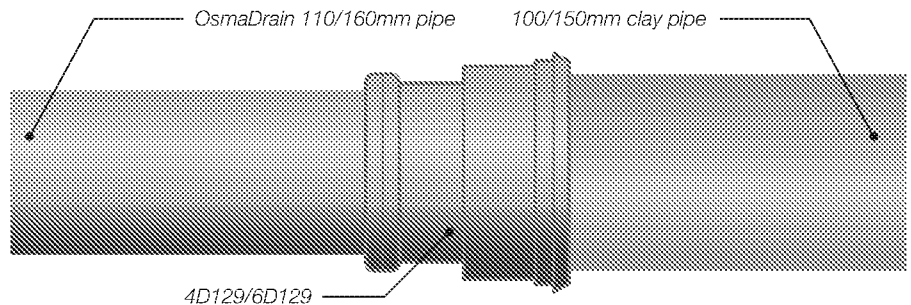
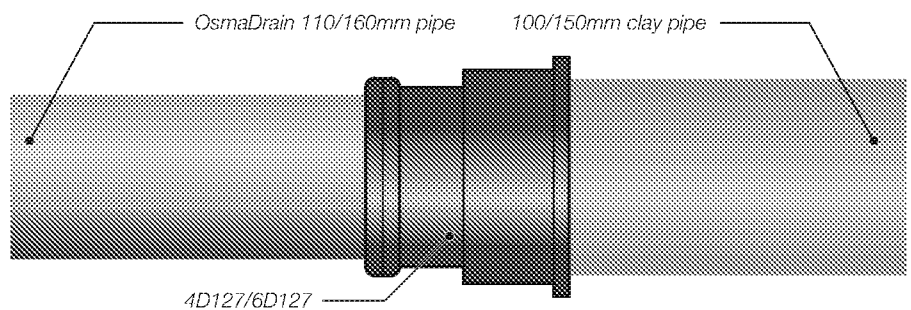

Figure 35: Connection to thick-wall clay spigot



Wall Protection Sleeve

Installation of Wall Protection Sleeve

1. Pack the space between the Sleeve and the wall with mortar or concrete.
2. Lubricate the pipe well before positioning it through the sleeve.
3. Place Couplers (4D/6D205) within 150mm of each side of the wall face. The length of the next 'rocker' pipe should not exceed 0.6 metre (See Figure 36). This will compensate for any settlement which may occur.
4. If abnormal settlement is expected incorporate several 'rocker' pipes. Complete with flexible joints (see approved document H, H1 diagram 7).

Figure 36: Installation of Wall Protection Sleeve

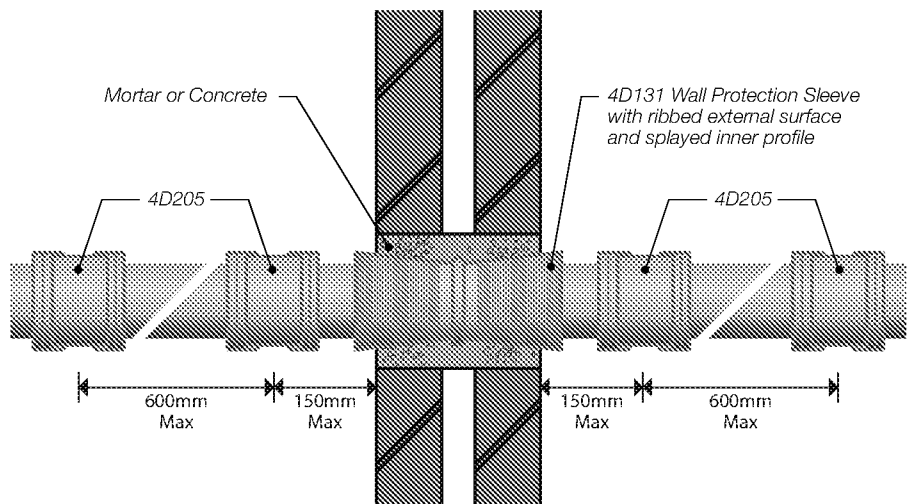

Slotted Rigid Pipe

Installation of Slotted Rigid Pipes

French Drain

1. Install Slotted Pipes as other OsmaDrain pipes (see Installation page 37, Figure 6) but use a selected permeable fill as bedding, sidefill and backfill material.
2. Do not compact the backfill.

Septic Tank Leach Pipe

OsmaDrain Slotted Pipes may be used to dispose of septic tank effluent by subsurface irrigation (See Figure 38). However, you should always consult the septic tank manufacturer for advice on the correct specification of pipe to use.

1. Lay pipes in trenches with a uniform gradient not steeper than 1:200 from the septic tank outlet.
2. Install unperforated OsmaDrain pipe with a fall of 1:30 for the first 3 metres. Installing an Inspection Chamber at this point will make it easier to monitor land damage.
3. Lay the pipes on, and surround them with, a 150mm layer of clinker, clean gravel or broken stone 20mm – 50mm grade.
4. Place a layer of polythene sheet over the slotted pipe before backfilling.
5. Do not use pipes manufactured in accordance with BS 4962 (OsmaDrain Subsoil Drainage) for disposing of septic tank effluent.

Figure 37: French Drain

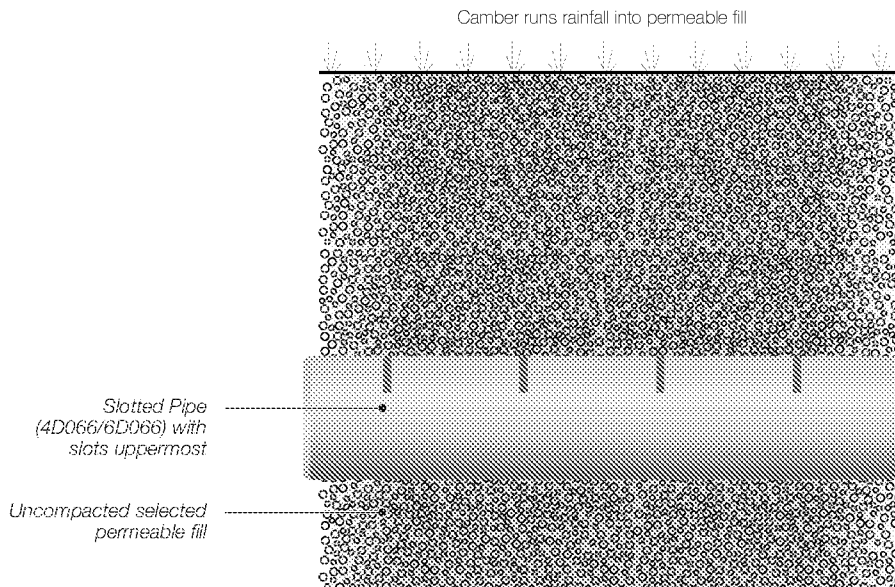
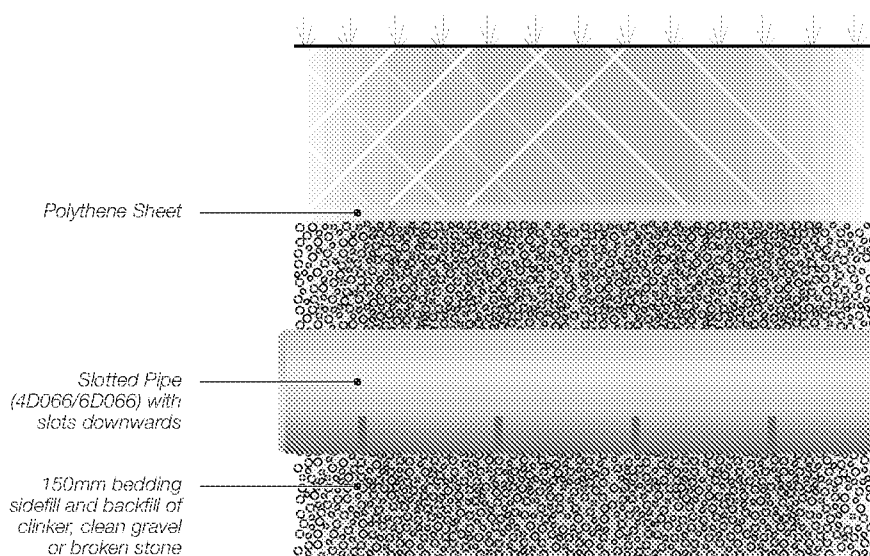

Figure 38: Bedding of slotted pipes for disposal of septic tank effluent



OsmaDrain

Testing, Safety and Maintenance

Testing

All lengths of the drain must be inspected for straightness, obstructions and for ground water infiltration.

They must also pass the following tests which must be carried out in the presence of an Authority's Inspector.

Water test

For pipes up to 300mm diameter the system should be filled with water up to a depth of 500mm above the lowest invert in the test section and a minimum depth of 100mm measured at the highest invert in the test section. This may be left for a period (one hour is generally sufficient) to condition the pipe. The test pressure should then be maintained for a period of 30 minutes, by topping up the water level as necessary so that it is within 10mm of the required level throughout the test. The losses per square metre of the surface area should not exceed 0.15 litres for test lengths with only pipelines or 0.20 litres for test lengths including pipelines and manholes, or 0.40 litres for tests with only manholes and inspection chambers alone (i.e. no pipelines).

Air test

For pipes up to 300mm diameter, the pipe should be pressurised up to a pressure of 110mm water gauge for and held for approximately 5 minutes prior to testing. Following this the pipe should be able to hold an initial 100mm pressure with a maximum loss of head on a manometer of 25mm in a period of 7 minutes.

Smoke test

Smoke tests are not officially accepted tests but are used to detect leakage points after other tests have failed.

Certain smoke canisters are not suitable for use with PVC-U drainage systems. Obtain the advice of the canister manufacturers before testing by this method.

Safety

The relevant regulations detailed in the Health and Safety at Work Act 1974 must be adhered to on site.

Solvent Cements, Fillers and Degreasing Cleaners

When making solvent weld joints, it is essential to observe normal safety rules for handling solvents.

- ⊙ Never smoke or bring naked flames near the area of work.
- ⊙ Work in a well ventilated area to avoid inhaling fumes.
- ⊙ Close the solvent container after use and store in a cool place.
- ⊙ Do not allow solvents or cleaners to come into contact with the skin.

Handling and Trench Safety

- ⊙ Take care when removing pipes from bundles as the straps are under considerable tension and may flail when cut.
- ⊙ Follow the relevant British Standard Codes of Practice and Sewers for Adoption when digging trenches to prevent accidents from trench collapse.
- ⊙ Use the correct fencing and marking whenever a trench is accessible to the public.

Maintenance

The smooth bore of OsmaDrain pipes combined with their long lengths reduce the risk of blockages. However if a blockage does occur, use only flexible or roller type rods. Pointed or boring type metal fittings are NOT recommended. Tests have been carried out on PVC-U pipes and fittings from specialist drain cleaning contractors and their normal equipment is suitable. Do not use specialist cutting attachments.

Building Regulations and Local Authority Bylaws state that rodding eyes must be provided to give ready access to underground drains for maintenance and cleaning.

Check the complete drainage system periodically and clean, making good any defects if necessary.

Bottle Gully

The OsmaDrain Bottle Gully allows easy rodding of the drain through the Gully itself. Using the Bottle Gully saves the expense of providing a bend with access plus a purpose made cover and frame (See Figure 39).

To obtain access to the drain, lift the grating by inserting a screwdriver under its edge, and simply lever out the removable access plug (See Figure 39).

Before replacing the plug, clean all mating surfaces.

Figure 39: Rodding through Bottle Gully

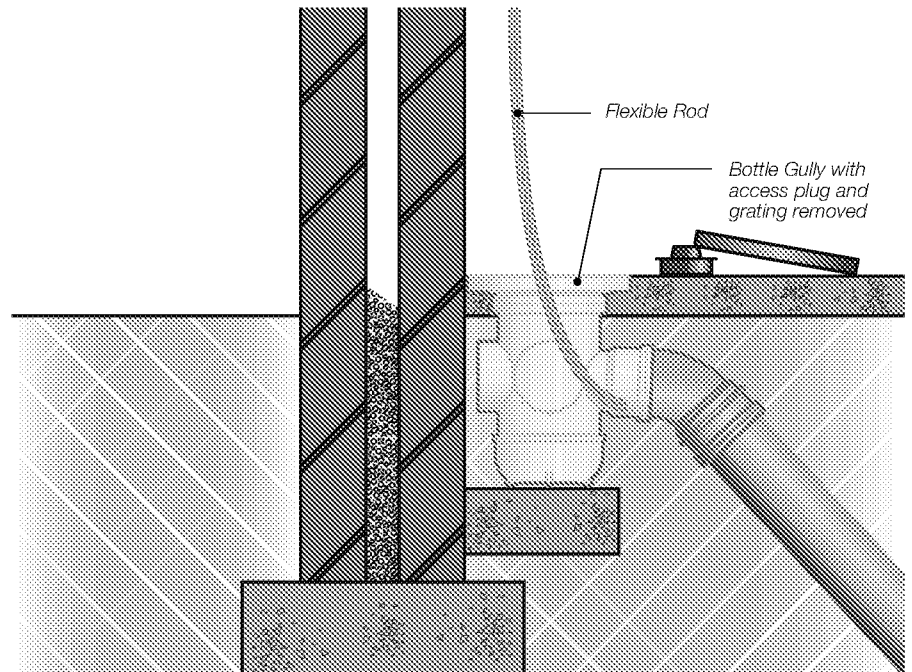

Water jetting

For guidance on good working practice when using water jetting equipment for the unblocking and cleaning of all types of drains and sewers refer to the WRc Sewer Jetting Code of Practice, 2nd Edition, Sections 5.4.2., 5.4.3. and 5.4.4.

Copies are available from:

Publications
WRc plc
Frankland Road
Blagrove
Swindon
SN5 8YF



OsmaDrain

Further Information

Wavin Knowledge Centre

Keep ahead of breaking news with a fresh and insightful look into the construction industry. Our aim is to keep you informed and up to date with the latest how-to guides, regulations, innovation and more. Visit blog.wavin.co.uk

CPD Training

Develop your knowledge and keep up to date with our range of CPD presentations. To see what courses are available and to book, visit wavin.co.uk/cpd

'How to' Videos

To accompany this brochure, there are a series of 'How to' videos to show how you can make light work of installation problems. They can be viewed at youtube.com/WavinUK.

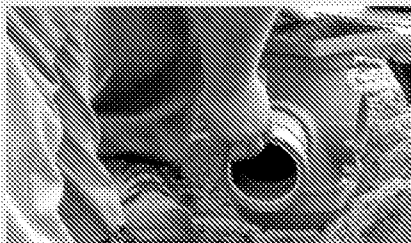

Discover our broad portfolio at www.wavin.co.uk

Hot & Cold Water

Foul Water

Gas & Water Mains

Indoor Climate

Storm Water

Geotextiles

Soil & Waste



Wavin is part of Orbia, a community of companies working together to tackle some of the world's most complex challenges. We are bound by a common purpose: To Advance Life Around the World.



Wavin Limited | Registered Office | Edlington Lane | Doncaster | DN12 1BY
[REDACTED] | www.wavin.co.uk [REDACTED]

Wavin operates a programme of continuous product development, and therefore reserves the right to modify or amend the specification of their products without notice. All information in this publication is given in good faith, and believed to be correct at the time of going to press. However, no responsibility can be accepted for any errors, omissions or incorrect assumptions.

© 2022 Wavin Wavin reserves the right to make alterations without prior notice. Due to continuous product development, changes in technical specifications may change. Installation must comply with the installation instructions.