

LEGEND:

- Existing wall
- New wall
- To be demolished
- Walls / structure above

- NOTES:**
- This drawing is for planning purpose only and not for construction.
 - Unless evident during the survey the existing drawing assume the building lines are perpendicular to each other and not diagonal
 - Drawings can be scaled where dimensions are not provided for Planning purpose only.
 - All internal finishes and fittings to be used is the responsibility of the client. Any layouts on these drawings are for indicative purposes only.

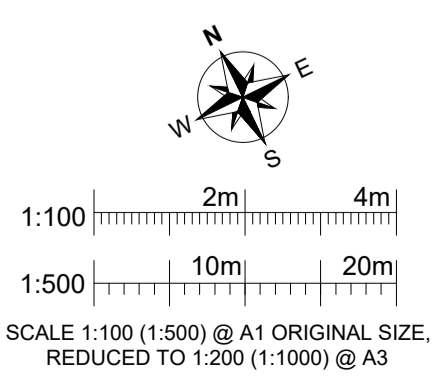

B	07/02/2026	Boundary distances added	GJ
A	07/02/2026	Issued for approval	GJ
-	11/11/2025	Issued for pre-planning comments	GJ
Rev	Date	Description	By
Client: Open Mind Empire LTD			
Project: 54 Richmond Avenue, Bognor Regis PO21 2YF			
Title: Single Storey Rear Extension, Loft Conversion with Dormer and Change of Use to 8-Bedroom HMO			
Status: PLANNING			
Designed by: GJ		Date: Oct 2025	
Scales @ A1:		1:100 1:500	
Drawing No: 250907 - 3.01		Rev: B	